



Garage Equipment & Tools For Commercial Vehicles

Catalogue - 2023-24

MADE IN **ITALY**



Technology Behind the Wining Power

One Stop Solution for

Garage Equipment and Garage Tools

Sarveshwari Technologies Ltd.

www.garageequipments.com



Quality Reliability Service...



ENGINEERING INNOVATION DESIGN

Sarveshwari popularly known by its brand name **sarv** is recognized worldwide as the leader in providing top quality garage tools and accessories for automotive & tyre service industry. We have been delivering niche workshop tools and accessories in more than 70 countries in 6 continents for more than 35 years.

We **manufacture** a large range of Wheel Balancing, Alignment & Tyre Changing Accessories, to suit majority of Garage Equipments like Wheel Balancing Machines, Wheel Alignment Machines & Tyre Changing Machines from all over the world. Our experience in development and manufacturing of products, has helped us to become a reliable & the preferred partner for OEMs worldwide. Other **sarv** products dominating the automotive after market & Tyre Industry include Rubber Pads, Tyre Service / Repair / Valve Tools.

Proudly we are the ONLY company in India to manufacture and export such wide range of Wheel Service Accessories.

DOMESTICALLY **sarv** is known for its world class quality Garage Equipments and their efficient after sales service. In the domestic market too, like the rest of the world, **Sarveshwari** is recognized as the leader for good quality tyre service tools and equipments.

We offer products from world class leaders namely CEMB-Italy, Space- Italy to distribute & service their Wheel Alignment Machines, Wheel Balancing Machines, Tyre Changing Machines, Vehicle Lifts, Nitrogen Generators and other Garage Equipments.

With wide range of international client base network, consider **Sarveshwari** as your single point service provider for all your workshop and tyre related problems.



Sarveshwari Group

Sarveshwari Engineers

Manufacturers and Exporters of Garage
Tools and Accessories
www.sarveshwari.com

Sarveshwari Technologies Ltd.

Workshop Tools & Equipments
www.garageequipments.com

RANGE OF

GARAGE EQUIPMENTS

FOR



TABLE OF CONTENT

WHEEL ALIGNMENT EQUIPMENT	02	OIL & GREASE CONTROL	21
WHEEL BALANCING EQUIPMENT	04	DIAGNOSTIC EQUIPMENT	23
TYRE CHANGING EQUIPMENT	05	WHEEL NUT RUNNERS	26
EXHAUST EXTRACTION SYSTEMS	06	TYRE MOUNT DE-MOUNT TOOL KITS	27
DPF CLEANING MACHINE	08	OTR BEAD BREAKER / TYRE PASTE AND BRUSHES	29
VEHICLE LIFTING EQUIPMENT	09	TYRE SERVICE TOOLS	30
GEAR BOX TROLLEY	12	TYRE VALVE TOOLS	33
HYDRO PNEUMATIC JACK	13	TYRE PRESSURE GAUGES	34
BUS WINDSHIELD INSTALLER / REMOVER	14	TYRE REPAIR TOOLS & KITS	36
TYRE CARE EQUIPMENT	15	TYRE REPAIR EQUIPMENT	37
NITROGEN GENERATOR & INFLATORS	18	TYRE & TUBE REPAIR PATCHES	38
WHEEL CHANGE KIT	19	UNIVERSAL TYRE REPAIR KIT	40
WORKSHOP EQUIPMENT	20		



DWA1100WE

Wheel Alignment Machine

8-CCD Sensor Truck Alignment System

Unique Features :

- Wheel alignment system for trucks and buses. Unit complete with cabinet, computer control system, sensors and all accessories required for alignment operations.
- CCD (Charged Couple Device) sensor technology, featuring state-of-the-art electronic componentry, enables a quick and accurate measurement of all alignment parameters by simply following a procedure field tested through many years of experience.



Database :

The CEMB database contains more than 55.000 vehicles and is constantly updated.



Lithium Batteries :

The batteries are immune to the "memory effect" and can be recharged at any time.



BT² Radio Communication 2,4 GHz :

The radio communication between sensors and computer uses a frequency of 2,4 GHz.



Featherweight Sensors :

Featherweight sensors: ONLY 2.8 KG



Dedicated Electronics :

The system features an industrial type computer, Windows based, solid state SSD Sata, USB interface. No moving parts (DVD/CD) that can cause problems.



User friendly Software :

Simple and user-friendly software
MAKES WORK EASY



Standard Equipment



x16



x4



- DWA cabinet, 19" TFT monitor, colour printer, keyboard, mouse.
- Industrial PC, with WINDOWS operating system
- Four car measuring heads with Lithium batteries, 8 CCD sensors, BT2 technology
- Four 4-point clamps 12"-24"
- c/w universal grips, L 45mm + metallic grips with reference surface, L48mm
- Brake pedal lock and steering lock
- Wheel alignment software and database for CAR.



Simple and user-friendly software



Adjust two axles in one screen

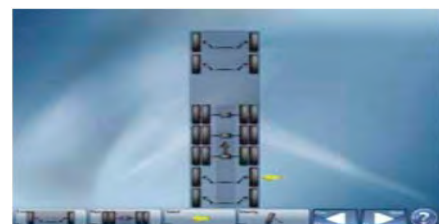

Step by step procedure up to 7 axles

ALADIN BTH (ART86BTH/ART98BTH)

MADE IN ITALY

Wheel Alignment Machine | Space-Italy

for Commercial Vehicles

Unique Features :

6CCD Alinger/ 8CCD Alinger.

- Simpler and more modern technology grants better reliability and less down-time for the end user.
- Bluetooth transmission between front heads and cabinet for faster information transfer
- Special supports on the side of the control unit permit housing and recharging the measuring-head batteries.
- LEDS on the head inform the operator when adjustment angle is within specification range.
- Data management and display program in windows environment.
- Ability to operate the system from any head. Often you are far from the console and this slows down the operating speed.
- Customer data bank for recording jobs with search by customer name or vehicle plate number.
- Build in vehicle database of different manufacturers worldwide with provision to add and edit.
- Faster and more reliable data transmission through Bluetooth (radio can be a problem on large vehicles).
- ART98BTH and ART86BTH represent the technology in truck alignment. These new development aligners feature state of the art components.
- Measurement of multiple axles vehicles, thanks to an extremely easy-to follow procedure.
- Software is just as complete but is much simpler to use and has a faster flow for the operator.
- Software is just as complete but is much simpler to use and has a faster flow for the operator.

- User's instructions by animated graphics for an immediate operation.
- Data management and display program in WINDOWS environment. Data bank with vehicle data sheets already
- Customer data bank for recording jobs with search by customer name or vehicle plate number.
- Summary and comparison of diagnosis/repair values on a single screen.

Technical Data		
	Accuracy	Total measuring range
Front Axle		
Total toe	+/- 3'	+/- 5°
Partial toe	+/- 1.30"	+/- 2°30'
Set-back	+/- 3'	+/- 5°
Camber	+/- 3'	+/- 10°
Caster	+/- 5'	+/- 18°
King pin	+/- 5'	+/- 18°
Rear Axle		
Total toe	+/- 2'	+/- 5°
Partial toe	+/- 1'	+/- 2°30'
Set-back	+/- 2'	+/- 5°
Total toe	+/- 2'	+/- 5°
Camber	+/- 2'	+/- 10°
Thrust angle	+/- 2'	+/- 5°



NOTE: ART86BTH RO-6CCD Sensors
ART98BTH RO-8CCD Sensors

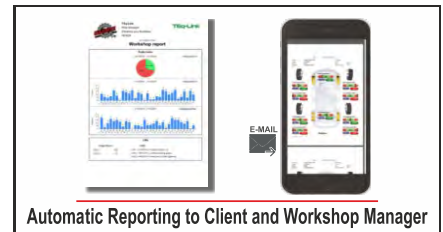
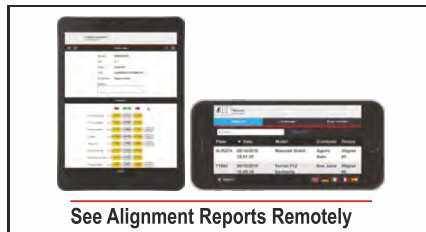
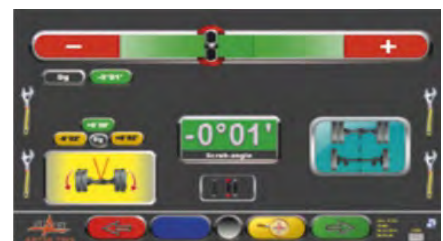

C-330

Wheel Balancing Machine

for Commercial Vehicles

MADE IN ITALY

Technical Data	
Max power consumption	1.1 Kw
Balancing speed	<80rpm
Balancing accuracy	10g
Cycle time for wheel	8-20sec
Diameter setting range	10"to 30"
Max wheel diameter	1380mm
Max wheel weight	250kg/200kg
Max air pressure	8-10bar

Unique Features : Lifting Spindle

the shaft rises and lowers to facilitate wheel loading by the operator and guarantees a perfect centring with minimum effort. Wheel, when raises, is already clamped on the spindle, in complete safety. The sliding trolley, with a height of only 59 mm, allows a faster and easier loading of the wheel, without the need for dynamic handling.

LA Sonar

device for automatic wheel width measurement without any contact.

Laser line

to facilitate the correct positioning of the adhesive counterweights in the 6 o'clock position, increasing the balancing accuracy.

Weight Tray

The sturdy rotational weight tray has been designed to make the most of the available space. The differentiated compartments allow a simple housing of cones, clamp weights, adhesive weights, grippers etc.

Electromagnetic Brake

The electromagnetic brake for the lock of the wheel in the exact weight position facilitates the balancing procedure.

Automatic Gauge

Extended gauge for diameter and distance measurement of rims up to 32".

Software

The software, entirely developed by CEMB, is easy to use and supports SPLIT, OPT and ALU programs.

Industry 4.0 Kit (optional)

allows a complete control of the workshop activity thanks to the possibility to plan the daily activity, by inserting the number of wheels, the start time of any activity and the machine that will be used to optimize the resources and eliminate waste of time. Interconnected system based on an operator panel assembled on the machine and a PC software (Tyre Shop 4.0) developed specifically for CEMB.



SCB-322

Wheel Balancing Machine



for Commercial Vehicles



Accessories

- **P-12001W (QTY 01)**
Cone 44-70
- **P1-12002W (QTY 01)**
Cone 59-82
- **P-12003W (QTY 01)**
Cone 78-111
- **P1-12004W (QTY 01)**
Cone 95-132
- **P1-50001 (QTY 01)**
Rubber Cap
- **P1-50000 (QTY 01)**
Quick Nut TR40*3
- **P3A-00203 (QTY 01)**
Cone 125-174 (LCV)
- **SCB322-F2 (QTY 02)**
Fuse 2A
- **3PT (QTY 01)**
3 Pin top (16A)
- **PP10*12 (QTY 5m -1,1)**
Pu Pipe 10*12 (with quick union 12-1/4 & Quick union 12-1/2)
- **11001/110009 (QTY 01 each)**
Wheel balancing weight plier standard / trucks
- **P3A-00102 (QTY 01)**
Spacer 1 (with alen bolts)
- **P3A-00202 (QTY 01)**
Cone 211-224 (4 hole assembly)
- **P5A-00001 (QTY 01)**
Spacer 2 (with alen bolts)
- **P5A-00002 (QTY 01)**
Cone 277-284 (5 hole assembly)
- **P3-61000 (QTY 01)**
Fixed nut wing nut 40*3 (Metallic)
- **Cal-SCB322 (QTY 01 each)**
Calibration weight 100g/200g
- **Fast 12*150 (QTY 04)**
Pin type anchor bolt (12mm by 150mm)
- **Test Weight (QTY 05 each)**
50g, 100g, 150g, 200g, 250g

Unique Features

- Automatic braking after spin.
- STOP pushbutton to stop the machine immediately
- Static and dynamic balancing modes.
- Rapid optimization (OPT).
- Exceptional stability in reading the unbalance between planes.
- No anchor-down installation.
- Automatic start/stop when the hood is lowered/raised.
- Movable low voltage control unit.
- Four ALU balancing modes.
- Self-diagnosis. Self-calibration.
- Display in grams or ounces, in mm or inch.



Technical Data

Power supply	220V/230V-1ph
Motor power	250W
Shaft diameter	40mm
Max wheel weight	200kg
Wheel diameter	1200mm
Rim diameter	10" - 32" (255 - 810 mm)
Wheel width	1.5" - 20" (39 - 510mm)
Balancing precision	± 10g
Cycle time	15s
Balancing speed	90 rpm for truck mode
Noise level	< 70 dbA
Air supply	8 -10 bar

DL-1500

Tyre Changing Machine | 
for Truck & Bus Tyres



Unique Features :

- Apply to rim dimension between 14" to 26".
- Lifting arm and universal chuck are all driven by the hydraulic pressure.
- Locking jaws with different gripping possibilities.
- Electrical control, move back and forth.
- Universal tool carrier arm with pendulous bead braking disc and hook.
- Movable low voltage control unit.
- Operation voltage 24V, safe and stable.



Technical Data	
Rim diameter	14" to 26"
Max wheel weight	500Kg
Max wheel width	780mm
Max wheel dia	1600mm
Hydraulic pump motor	1.5Kw, 400V, 3PH, 50Hz
Gearbox motor	2.2Kw, 400V, 3PH, 50Hz
Operating pressure	130bar
Bead breaking force	2500Kg
Operation control voltage	24V
Machine weight	570Kg

Accessories

220008 (Qty 01) Tyre lever 600mm	2200012 (Qty 01) Lever for removal of locking rings	220004 (Qty 01) Lever for tubeless tyre 800mm	2200313 (Qty 01) Rim clamp for tubeless truck alloy rim
220415 (Qty 01) Special brush for tyres with wooden handle for trucks & earthmovers	2200120 (Qty 01) Sarv paste 1 kg	DL1500-704 (Qty 01) Manual lubrication pump	DL1500-705 (Qty 01) Funnel for hydraulic / gear oil
Fast12*150 (Qty 05) Pin type anchor bolt (12mm by 150mm)	DL1500-510.1/510.3/510.5 (Qty 02 each) Fuse 1A, 3A, and 5A	IM DL1500 (Qty 01) Instruction manual	SM DL1500 (Qty 01) Spare part manual

TC-2500

Automatic Tyre Changing Machine | 
for Industrial, Agricultural and Earthmoving Tyres

Technical Data	
Rim diameter	14"-42"
Max. wheel weight	1600kg
Max. wheel width	1050mm
Max. tyre diameter	2300mm
Hydraulic pump motor	2.2kW 380V-3Ph-50Hz
Gearbox motor	2.2kW 380V-3Ph-50Hz
Bead breaker force	3300kg
Operation control voltage	24V
Machine weight approx	758kg
Overall dimensions approx	2500×2000mm
Power	3Ph, 400V, 50Hz
Gross weight	850kg
Outside dimension (L×W×H)	2130×1850×1090mm



Unique Features :

- Motorized Universal Tyre Changer for Truck , Bus, Industrial, Agricultural, and Earthmoving wheels for Rim sizes from 14" to 42"

TC-3500

Super Tyre Changer | 
for Industrial, Agricultural and Earthmoving Tyres



Technical Data	
Rim capacity	14"-46"
Rim capacity with extensions	14"-56"
Max. wheel diameter	2500mm
Max. wheel width	1200mm
Max. wheel weight	2000kg
Hydraulic unit motor	2.4/3.0 Kw
Gearbox motor	2.4/3.0 Kw
Machine weight approx	1145 kg
Power	3Ph,400v, 50HZ

Unique Features :

- Super truck changer has been specifically designed to mount and demount truck, bus, tractors and earthmoving vehicles tyres with rim capacity 14"-56"
- It has bi-directional chuck with 2 rotational speeds.

HOSE REEL EXHAUST EXTRACTION SYSTEMS

For BS6 Workshops For Both Regeneration and Working Bay upto 700°C

Unique Features :

- SARV's Vehicle exhaust extraction system extracts exhaust from the vehicle muffler and prevents toxic high temperature exhaust fumes from being dispersed in the workshop environment and becoming a danger for the operator & his health.
- Specially designed For BS6 Workshops For Both Regeneration and Working Bay upto 700°C



LTES2-10M



HTES7-10M

Two type of **EXHAUST EXTRACTION SYSTEMS**

- Hose Reel Exhaust Extraction System-200°C (LTES2-10M)
- Exhaust Extraction System-700°C (HTES7-10M)
- Mini Set Exhaust Extraction System-200°C (LTESM2-10M)
- Exhaust Extraction System-700°C (HTESM7-10M)

Designing a HEALTHIER WORK ENVIRONMENT

DESIGN AND MANUFACTURED sarv Professional Tyre Tools & Equipments Since 1991

Advantages :

- Coupled driven motor
- Stainless steel fan construction
- End to end installation support
- European made hoses
- Speedy after sales service
- Patented universal trolley
- Crompton greaves motor

sarv PATENTED UNIVERSAL TROLLEY

Suitable for all Vehicles :

- Horizontal Exhaust
- Vertical Exhaust
- Centre Tailpipe Exhaust

SARV-150AU



Silent Features

- Stainless steel suction
- Intake for high temperature
- Double braking wheel low ground clearance

Dimensions

- Vertical lifting height : 3650mm
- Horizontal length : 1400mm

IN HOUSE MANUFACTURING

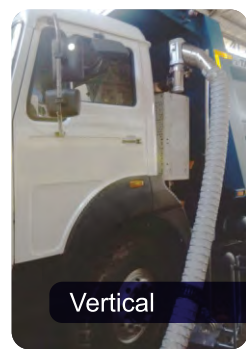

Vertical



Horizontal



Centre Tailpipe

MINI SET EXHAUST EXTRACTION SYSTEMS

For BS6 Workshops For Both Regeneration and Working Bay upto 700°C

The MINISSETS are the simplest expression of a fixed gas extraction system.

Consist of :

- Centrifugal Fan,
- Hose
- Nozzle for intercepting the gases



VIDEO DEMO



Clean Air at Work



Installation Images





STL-DCE (L) DPF CLEANING MACHINE

Fully Automatic System, Cyclone System applied | 

Unique Features :

- Fully Automatic Chemical Cleaning.
- Pressure Cleaning.
- Differential Pressure Cleaning.

Technical Data	
Product Name	STL-DCE (L)
Count	5~60 times (by 1 times)
Air Time	0~30 sec (by 1 times)
Water Time	0~30 sec (by 1 times)
Input Voltage	110~240V 50/60Hz, Single Phase
Weight (Kg)	140 Kgs
Dimension (mm)	1000x500x1200 mm

DPF equipment operated manually and automatically.

Applied Cyclone System

which doesn't splash water.

DIFFERENTIAL PRESSURE TEST USING
DIFFERENTIAL PRESSURE SENSOR HOSE



DISPLAY DIFFERENTIAL PRESSURE BY WAVEFORM

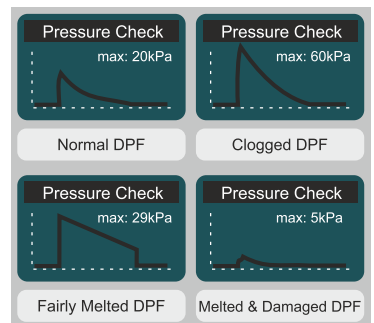

THREE STAGE FULLY AUTOMATIC CLEANING

Soaking > Blowing > Cleaning - Able to set water injection time, air cleaning time and count

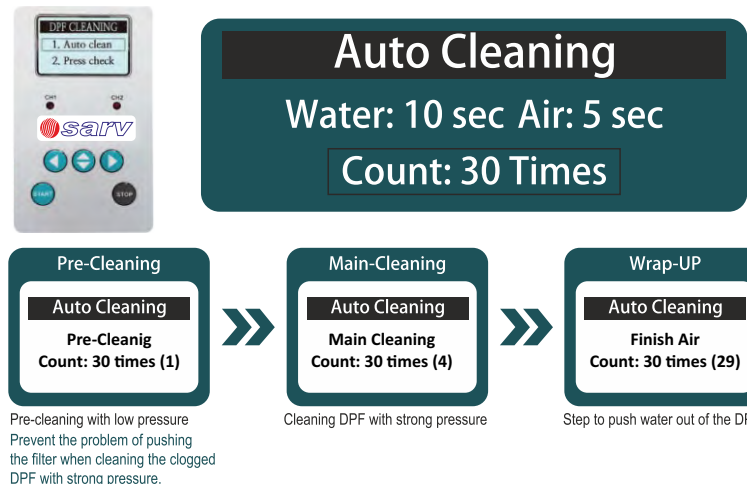

ABLE TO CLEAN LARGE DPF



DPF CLEANING BEFORE / AFTER

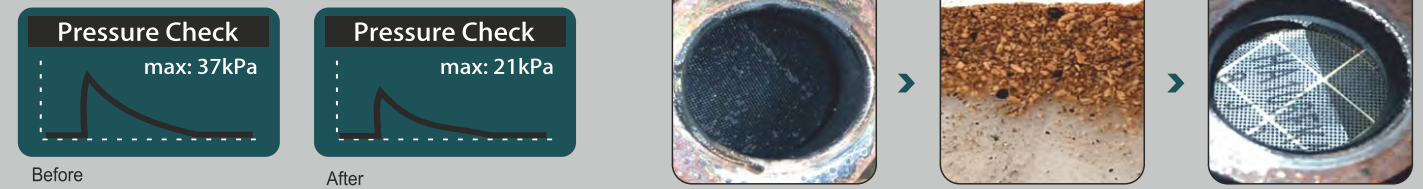

ST-2PLC40 BP

Two Post Lift | **sarv**
for Cars & LCVs

Technical Data

Lifting Capacity	4T
Lock Release Type	Manual Release
Lift Height	1825mm
Lifting Time	50sec
Height of Post	2725mm
Motor Power	2.2kw
Power Supply	380V / 220V

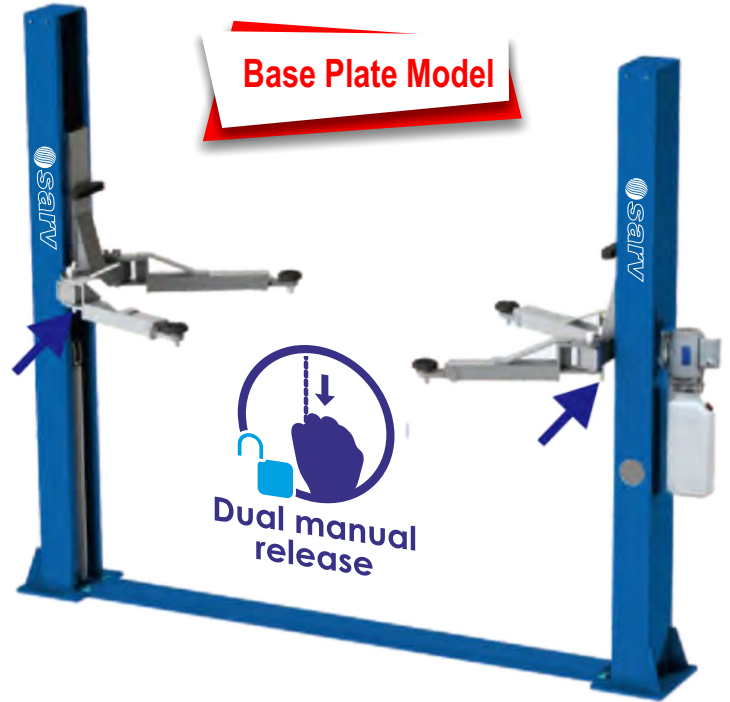

Clear Floor Model

ST-2PLC40 CF

Two Post Lift | **sarv**
for Cars & LCVs

Unique Features :

- SARV's 2 Post Lift for Cars for General Maintenance
- Rugged and Sturdy 2 Post Lift for Cars & LCVs
- Sarv's 2 Post Lift makes the service work easy for operators to move toolboxes, transmission jacks, oil drains etc under the lifted vehicle.
- Automatic release from one side.
- Base plate presence designed specifically for low ceiling work shop.
- Dual hydraulic "Direct-Drive" cylinders.
- Heavy duty carriage for superior strength and durability.
- Drop-end arms provide a lower pad height.
- Electric / Hydraulic power system.
- Heavy-Duty equalizer cables with over size cable sheaves.
- Truck and van adaptors standard.
- CE approval with strict EC type examination

Dimension

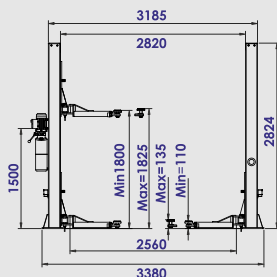

Base Plate Model

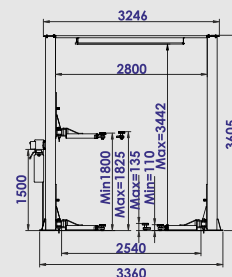
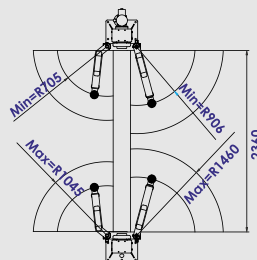

Clear Floor Model

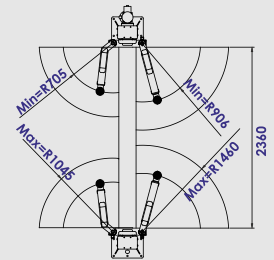

ENGINE & GEAR BOX LIFTING CRANE SUJC-2T

Heavy Duty Mobile Hydraulic Engine & Gear Box Lifting Crane | 
for Trucks & Buses



CAPACITY:
2 Ton



OVERALL HEIGHT:
2700mm



AVAILABLE MODES:
Hydraulic with manual lock



EASY LIFTING:
Hydraulic operation provides easy lifting to desired height.



NEW DESIGN:
Designed for shops with limited space and for maximum portability.



HEAVY DUTY:
Heavy Duty engine crane with reinforced leg assemblies for added strength and durability.



WEIGHT:
500 kgs

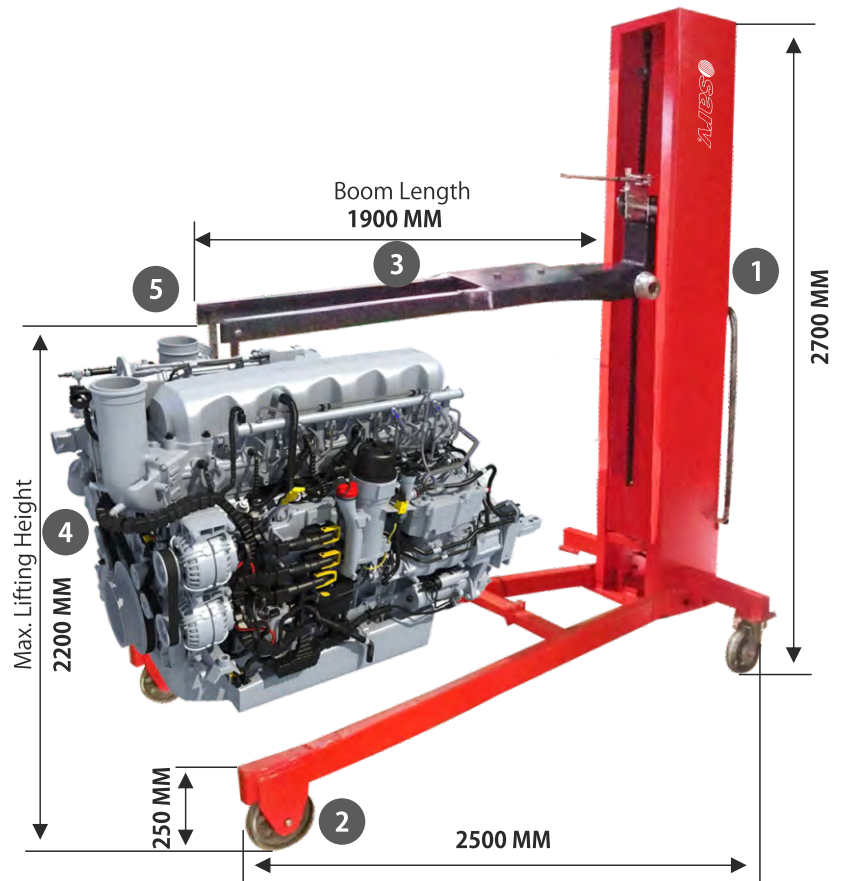

USE

- Heavy Duty Hydraulic Engine Lifting Crane Designed and Manufactured by SARV easily mantles & dismantles heavy weight Diesel Engines and gearbox from small and crowded Truck and Buses engine compartments and front show vehicles.
- Extremely easy to operate because of Hydraulic lifting reducing the overall breakdown and overhauling engine time. Spray painted for rust free application.
- Essential for your vehicle repair shops as it is capable of lifting the engine and gearbox together at once.

1

Single Pump Hydraulic operation makes the lifting mechanism extremely easy for the operator.

2

Comes with 4 Castor wheels with locking mechanism for hassle free parking.

3

Two Boom design gives extra strength to the crane's lifting capacity. Boom Length can adjustable.

4

900 from the floor lifting of the engine & gear box directly on the boom without any tilts eliminates any possibilities of slippage.

5

Chain locking system for supporting engine and gear box.

SCR-202T, 203T

JIB Crane | 
for Trucks & Buses



Note: Foldable Model. Easy For Storage

Technical Data

Lifting Height	280mm (min.) 1840mm (max.)
Boom Length	1180mm
Boom Extension	780mm
Length	max 2000mm min 1450mm
Closed Height	1550mm
Chain Length	410mm
Operating System	Hydraulic Hand Operated
Load Carring Cap.	2/3 Ton
Overall Weight	140 kg

SMCL-55/ SMCL-75/ SMCL-85

Heavy Duty Column Lift | **sarv**
for Trucks, Buses & OTRs

Unique Features :

- 4-column, 6-column
- Remote control handset with 10 metres cable
- LCD screen shows the exact lifting height and fault diagnosis, etc
- Adjustable wheel support for all kinds of wheel sizes
- Each column is equipped with it's own control system, applies to four, or six, or eight columns per set.
- The hydraulic electric system provides safe and accurate real time control.
- With up-to-date technology, SCM control system ensures the lifts' synchronization.
- Double safety system: mechanical lock and hydraulic check valve.
- Fixed wheel supports or optional adjustable ones at your choice.
- Mobile and flexible, the system can be used indoor or outdoor.
- Waterproof design for use in commercial wash bays.



Technical Data	
Lifting capacity	5500/ 7500/ 8500 kgs per column
Motor power	1.1 KW
Max. lifting height	1700mm
Time for lifting or lowering	120s/100s
Power supply	400V/ 415V, 50Hz
Motor power	2.2 KW per column
Weight	580kgs per column
Lifting system	Hydraulic
Dimensions	226cm (H)*110cm (W)*120cm (L with Hydraulic trolley)

Wireless Option Also Available*

HRJS-12Y

High Rise Jack Stand | **sarv**
for Trucks & Buses

Unique Features :

- Used to support raised heavy duty vehicles, to facilitate maintenance and inspection procedures.
- The support stand is designed to be used in sets of 4, 6 or 8 and must be placed under a level, raised vehicle, at the support points designated by the vehicle manufacturer.
- Jack Stand features a double locking pawl and tooth design for extra protection.
- The one piece multi position ductile ratchet bar provides super strength and durability.
- The quick adjustment mechanism securely locks it into the desired location hence providing superior safety.



Technical Data	
Capacity	12 Ton
Minimum height	1295mm
Maximum height	1905mm
Base diameter	711mm
Weight	78kg



4P04LT12T/ 4P04LT16T

Heavy Duty Four Post Lift
Electro-Hydraulic with Runway | **sarv**
for Trucks & Buses

Unique Features :

- Flat runway design, optional rear side slips and jacking beams for wheel alignment using safety locks, manual release
- Strong hydraulic cylinder, heavy duty steel carriage
- Option available for Pneumatic also



Technical Data		
Models	4P04LT12T	4P05LT16T
Lifting capacity	12T	16T
Track length	7620mm	8386mm
Lift height	1700mm	1700mm
Track width	650mm	700mm
Motor power	3kw	3kw
Power supply	415v	415v

HEAVY DUTY UNIVERSAL HYDRAULIC TROLLEY

ST-HTJ01

Universal Trolley for lifting **ATS gear box with retarder & crown** | **sarv** **BEST SELLER**
for Commercial vehicle

- 1 The trolley is easily portable by single operator because of 360 degree swivel steel casters. Provided with a towing handle for easy carriage.
- 2 Easily Adjustable head plate with four adjustable quick-ratcheting brackets. Support plate can be tilted forward, backward, side to side, and extended or contracted for optimum alignment of bolt pattern and pins of all three equipment.
- 3 Mechanically lifted with help of safety bar. Precision Valve holds the trolley in position.
- 4 Mechanical locking ensures safety of gear box in case of any hydraulic failure.

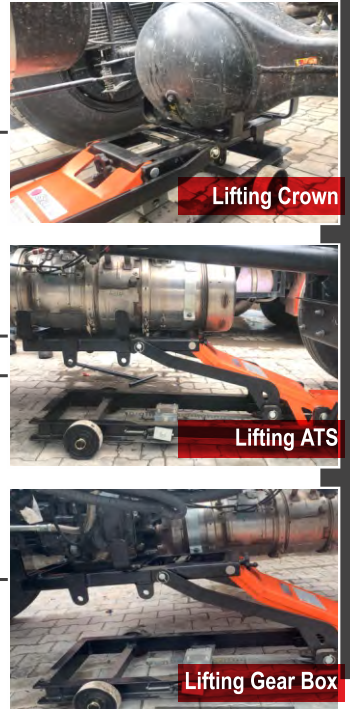

IN HOUSE MANUFACTURING

DESIGN AND MANUFACTURED | **sarv**
Professional Tyre Tools & Equipments Since 1991

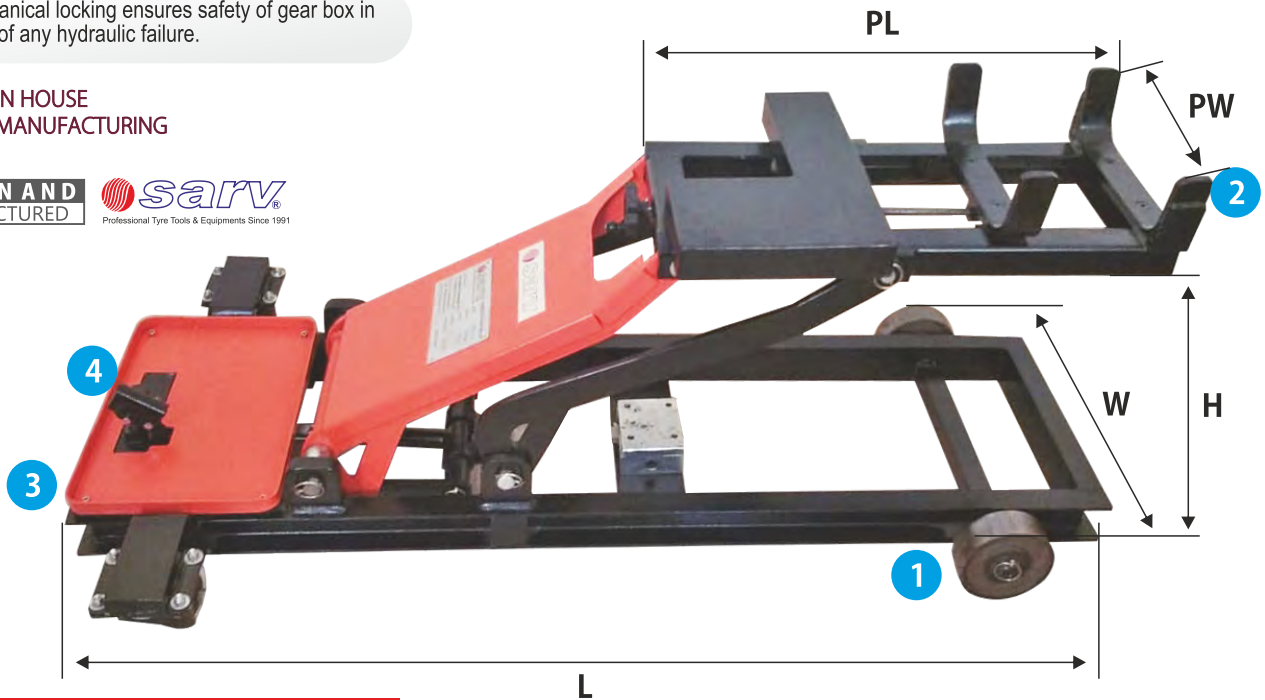

TECHNICAL SPECIFICATION

	CAPACITY: 1Ton		CASTORS: Four castors for extra manoeuvrability.		PLATFORM LENGTH (PL) & WIDTH (PW): Min. 710mm, Max. 1045mm Max. 410mm
	WIDTH & LENGTH: W-810mm L-1580mm		ALSO SUITABLE : For BS-IV and BS-VI Engines		LIFTING HEIGHT (H): Min. 200mm Max. 800mm
	WEIGHT: 140kg		SAFETY CHAIN: Safety chain secures gear box in place during removal and transport		

Sarv's Universal Trolley is Innovative and advanced hydraulic 3 in 1 trolley for removal and installation of Gear Box with retarder, ATS and Crown for Commercial Vehicles with ease.

Operators can save time, cost and space by eliminating the need to keep three separate trolleys.

Manufactured with high quality MS steel, is robust, stable and extremely sturdy for long time and continues workshop use. The trolley frame is built in 8mm Steel body which provides extra stability. It is powder coated for anti rust finish.

HYDRO PNEUMATIC JACK ST-25/50T | ST-15/30T

Hydro Pneumatic Trolley Jack |  **BEST SELLER**
for Trucks & Buses



UNIQUE FEATURES :

- Slow down valve
- Imported sealing from USA
- Hard chrome plated both internal & external cylinder
- Safety overload valve
- Self-return switch for safe working
- XTP industry sealing (double sealing function)
- Oil anti-back system



• **ST-25/50T**



• **ST-15/30T**



	Capacity	Net Weight	Packing Size	Working Air Pressure	Min. Height	Max. Height	Lifting Height	Extension Height
STLS50-2J	50 Ton/25 Ton	67kgs	84x29x29mm	0.9~1.2mpa	215mm	564mm	50T - 115mm 25T - 114mm	75mm + 45mm
STLS30-2	30 Ton/15 Ton	32kgs	70x29x27mm	0.9~1.2mpa	150mm	413mm	30T - 74mm 15T - 69mm	75mm + 45mm

BUS WINDSHIELD INSTALLER / REMOVER



3500TS EVO 2.0 | sarv

Max load cap. : 280 Kg
Max height : 3.24 m

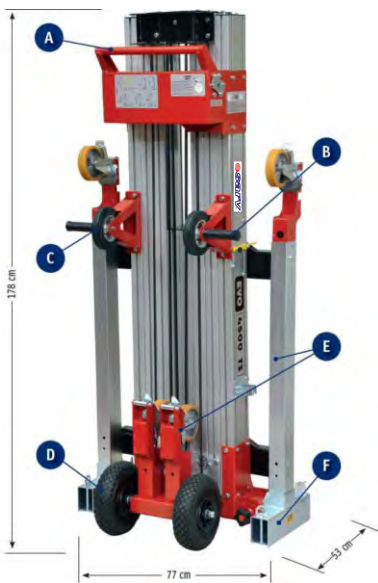
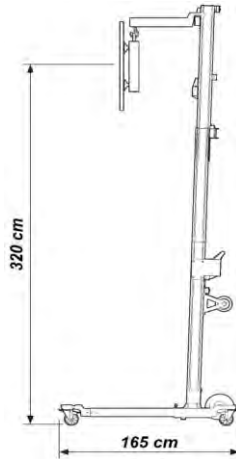

- A** Handle for moving and transporting the machine: the raised position simplifies handling and is less tiring for the operator
- B** Handlebars for steering the machine during work: positioned externally so as to make the machine easy to handle when fully loaded
- C** Wheels for loading/unloading the machine in the transport configuration: the position has been designed to make the machine easier to load/unload onto/from trucks.
- D** Inflatable tyres for facilitated operation over rough ground in the transport Configuration
- E** Feet (with castors and brakes) fitted into the base with quick couplings: besides reducing the size of the machine in the transport configuration, the 4 feet can also be removed so as to lighten its overall weight and allow it to be transported and lifted more easily
- F** Extensible base. There are two positions: one for transport (77 cm, allowing the machine to pass through narrow doors in the transport configuration) and one for work (116 cm so as to guarantee maximum stability even with a full load and at maximum height).



ACCESSORIES NEEDED FOR WINDSHIELDS INSTALLATION



Endless screw side shaft that allows right & left moving of windshield



Single fork L. 450mm



Suction cups group (3 cups) with glass stop



MOTOCO
The lifting system (patented) foresees the possibility to use a battery drill or, on request, a 220v gear-motor



ST-440GT

Tyre and Tube vulcanizer | sarv
for Trucks & Buses



Unique Features :

- Used for passenger car, Truck Tire. Thermostatically controlled heat unit reaches operating temperature quickly for fast cure rates including tread.
- Repair different areas of passenger tires
- Three different size of plates for curing different sizes patch (upto5.5")
Dual controllable heating system

Components List

- Main pillar with tool box and control panel (1)
- Spotter Frame (1)
- Adaptor U Clamp (1)
- Heating Plates with electric wire (2)
- Counter Plates (5)
- Pliable Bags (2)
- Upper and Lower threaded rod (2)
- Socket Head Screw Key (1)



Technical Data	
Vehicle	Cars, LCV's, HCV's
Tyre Size	24"
Max Repairing Size	6 1/2"x 4 1/2"
Operating Temp	135°C ~ 150°C
Supply voltage	AC: 220V ± 10% (50 Hz)
Current Rating	5 A
Throat Depth	30"
Throat Height	34"
Repair areas of the tyre	Sidewall Shoulder Crown/Tread
Dimensions (L X B X H)	730x510x1850
Weight	55 Kg

SIC-5P

Tyre Inflation Cage | sarv
for Trucks & Buses



PROVIDE PROTECTION: These safety cages, a mandatory precaution for tyre inflation, provide protection in cause of tyre burst.



COLOUR:
Grey



DIMENSIONS:
920L x 700B x 1365H mm



WEIGHT:
130 kg



MAX. TIRE SIZE:
12"-48" OD/304-1219 mm OD



BARS:
Available in 5 bars



Used to safely inflate the tyres preventing injury to the operator in case of tyre burst.

***Also available in bigger size**



SAC7.5 / 10 / 15 / 20

Heavy Duty Two Stage Air Compressor | sarv
for Trucks & Buses

Unique Features :

- The Heavy Duty Reciprocating type Air compressor with Electric Motor.
- SAC 7.5/10/15/20 is a Two Stage, Three Cylinder Driven with Star/Delta Starter and mounted on air tank.
- Horizontal Air Receiver with Moisture Separator.



	Technical Data			
Models	SAC7.5	SAC10	SAC15	SAC20
No of cylinders	2	2	3	3
PD CFM	27.3	33.3	52	72
Working pressure	12 Bar	12 Bar	12 Bar	12 Bar
Power	7.5 Hp	10 Hp	15 Hp	20 Hp
Compressor LPM	773	941	1472	2050
Tank capacity	220/280 Ltr.	220/280 Ltr.	280/500 Ltr.	500 Ltr.

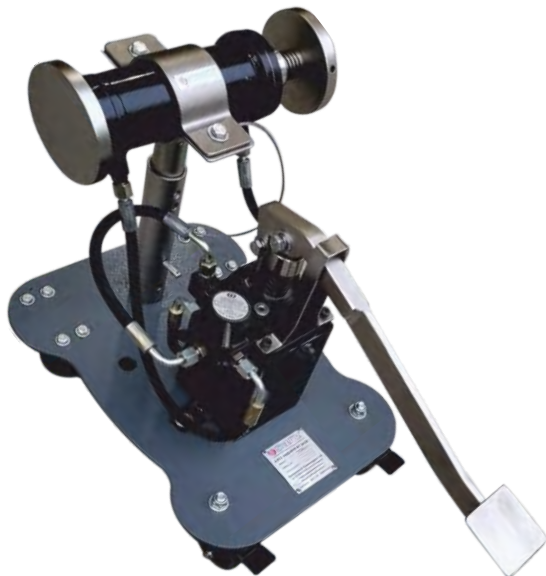

STLWAAJ-01

Wheel Alignment Adjustment jack | sarv

for Trucks & Buses

Size:

775x500x651 mm. (LxWxH)

(A) Jack Hydraulic Cylinder centre distance from Ground:

651mm (maximum)

(B) Hydraulic Cylinder Stock:

613mm (maximum) | 295mm (minimum)

IN HOUSE MANUFACTURING



DESIGN AND MANUFACTURED

sarv
Professional Tyre Tools & Equipments Since 1991

Scope of supply:

Sr. No	Description	Size	Qty.
1	Hydraulic Hose Pipe R2	1/4" BSP x length 800 mm.	1 Nos.
2	Hydraulic Double Nipple Male	1/4" BSP	2 Nos.
3	Wheel Nylon	3"	4 Nos.

- With Sarv's revolutionary Wheel Alignment Jack, adjust your Truck's Thrust and Scrub angles in less than 2 minutes!
- Eliminates all traditional methods of using Screw Jacks with bricks, which is not safe for the operator as well as tyres and is time consuming.
- Manufactured from high quality Aluminium to provide enough strength to distance the axles.
- Power coated for anti-rust finish

Hydraulically operated by a foot pedal.

The jacks curved arms take the leverage against the wheels to adjust the angles. Pedal it till the desired angle is reached.

It is light weight and portable. The castor wheels can be locked in position.

Weight: 35 kg
Oil Tank Upto: 2.5 Ltr.

S550T

Wheel Dolly | sarv

Unique Features :

- Perfect for 8-10 hole Budd tyre wheels.
- Budd Removes truck wheels and tyres fast and easy.
- Reduces manpower needs.
- Saves time and money, maintenance free.



CAPACITY WEIGHT:
150 kg



APPLY TO TYRE:
36" TO 48"



NET WEIGHT:
8 kg



GROSS WEIGHT:
10 kg



IN HOUSE MANUFACTURING



S650T

Wheel Dolly Hydraulic | sarv

Unique Features :

- The hydraulic system on this heavy duty dual wheel dolly makes it easy to remove and install dual wheel assemblies from even the largest truck.
- Tilt Frame and Rolling Lift Arms for easy positioning of dual wheel assemblies.



CAPACITY:
1 Ton



MODEL:
Hydraulic



NET WEIGHT:
61.50 kg



GROSS WEIGHT:
78 kg

STLPWT01

Pneumatic Impact Wrench Holding Trolley | sarv

for Trucks & Buses

It is used for holding 1" & ¾" Impact Wrench which is approximately 12-15kg of weight for easily assembling & disassembling of wheel nuts of Passenger Car/Bus/Trucks without much effort.



COLOUR:
Grey



BOTTOM PLATE:
Dia 550 mm



IMPACT WRENCH:
1" and ¾"



HOLDING WEIGHT:
12 - 20 kg



MEASUREMENT:
443 x 1250 x 500 mm

STL-HLJ20T

Hydraulic Long Floor Jack | sarv

for Trucks & Buses



Hydraulic Trolley Jack
10ton/20ton

Unique Features :

- Large heavy duty rear swivel caster wheels provides easy maneuvering and positioning of jack.
- Welded base and cylinders to assure strength and eliminated leaks.
- Chromed pump piston and ram for added rust resistance.
- Foot pedal brings saddle up to load quickly.

Technical Data

Capacity	10/20Ton
Min. height	200mm
Max. height	590mm
Net weight	130Kgs
Length of chassis	1700mm
Saddle length	700mm
Handle length	1300mm

STL-BJ-10/16T

Bottle Type Hydraulic Jack | sarv

for Trucks & Buses

Unique Features :

- Long functional life.
- Superior Performance top of form
- High Quality
- Safe Ratcheting heads
- Makes Big loads easy to lift
- Good Finish & Rust Preventive Coating

Technical Data

Capacity	10 Ton	16 Ton
Minimum height	240mm	235mm
Maximum height	490mm	490mm
Weight	10.65kg	11.05kg
Base (Min)	150x150mm	150x150mm
Base thickness (Min)	20mm	25mm
Saddle dia (Min)	45mm	45mm
Saddle thickness (Min)	15mm	15mm
Tommy bar (Min)	39"	39"





NITROPURE STL-G5-N₂

Nitrogen Tyre Inflation System | sarv

for Trucks & Buses

Unique Features :

- Generates nitrogen from compressed air
- Auto Shut-Off
- 2 Pre-Filters
- 118L/31.1gal (us) external nitrogen storage tank
- 1Nos*10m/32.8ft standard hose with 2 quick couplers to connect the unit and your tyre inflation gun
- Nitrogen purity test port
- Options available:
 - 118L/31.1gal(us) tank can be customised to 2pcs 14.5L/3.8gal(us) tanks
 - No need external tank for non painting

Technical Data		
Parameter/ Model	UoM	G5-N ₂
Nitrogen purity	%	95.5 - 99
Required input pressure	Kg/cm ²	12-14
N ₂ filling range	psi	0-174
Pre filter	Micron	5
Outlet Air pressure	Kg/cm ²	10-12
Including external Nitrog. storage tank	Liters	118
Power supply	VAC	230/1 ph/50 ±/10v
Net weight	Kgs	98
Overall dimensions	mm	620x400x1275



STL-ATI-W188

Automatic Tyre Inflators | sarv

for Trucks & Buses

Unique Features :

- Aluminium die cast housing.
- Vandal resistant mechanical switches for long life.
- Ceramic sensor for highly accurate.
- Easy, clear and accurate suitable for indoor or outdoor.
- Can inflate accurately with hoses up to 50m.
- Comprehensive diagnostics and error reporting.
- Ideal for quick lube centers, rental car facilities and automobile dealership.
- Standard device includes chuck and rubber hose.

Technical Data	
Reader Unit	Digital Display, audible warning
Chuck Type	Clip on
Chuck Style	Single Straight
Scale	0.5-13bar 7-188psi 50-1300kpa 0.5-13kgf
Inset Size	1/4" Female BSP/NPT
Dimensions	31L*30W*22H cm
Weight	1PCS/6KGS
Accuracy	±0.02bar ±0.3psi ±2kpa ±0.02kgf
Operation	Auto Inflation, deflate
Supply Pressure Max	16bar 232psi 1600kpa 16kg/cm ²
Supply Voltage	AC 110-240V/50-60HZ

Inflation Safe-LED Type
Wall Mounted Tyre Inflator
Available with Stand Also

Also available in

STL-ATI-W188 4W

High Flow Wall Mounted Inflator | sarv

Unique Features :

- Aluminum die-casting housing
- Vandal resistant mechanical switches for long life
- Ceramic sensor for highly accurate
- Accurate to within 0.02BAR (0.3PSI)
- Easy, clear and accurate suitable for indoor or outdoor
- Ideal for Fleet Operations, Tyre Service Centers and Tyre Mounters
- **With AW401 accessory can inflates 1 to 4 tyres simultaneously**
- Designed specifically for inflating large OTR tyres or multiple truck tyres



4 Way Manifold Kit
(4*2m hose with chuck)



MES1000

Metallic Separator | sarv

Unique Features :

Metallic Separator for Workshop Bays in order to prevent heat transfer compatible for BS6 workshop bay.

Technical Data	
Weight	60kg
A	1500mm
B	1200mm
C	100mm

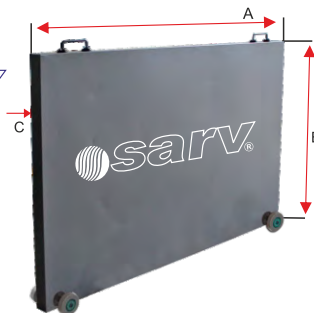

 IN HOUSE MANUFACTURING

ST-FB01

Industrial Vertical Fan Blower | sarv

Technical Data	
Axis Fan	710 Dia
Power	1.44kw (2HP)
Fan Type	Vertical
Suitable for	Industry
Color	Blue



 IN HOUSE MANUFACTURING

SUPERMAN WHEEL CHANGE KIT

Easiest and the Safest way from SARV to Completely change the Truck /bus Wheels on your vehicle!! This is a complete Kit which helps you remove the wheel from your vehicle, Change the tire, Inflate it and install it back on the vehicle!!



SCAN FOR DEMO VIDEO

KIT CONTENTS



Hydro Pneumatic Trolley Jack :

for lifting the vehicle.



Wheel Dolly :

For easy movement of the wheel while removing and installing from/to the vehicle.



Impact Wrench & Holding Trolley :

for loosening/Tightening wheel nuts. Pneumatic Wrench trolley makes it easy to hold the pneumatic trolley.



220603 Manual Tire Mount Demount Tool Kit :

for Manually changing tubeless tires with even hard rusted beads within 2 minutes.!



Tyre Bead Seater :

Bead Seater for seating the bead for tyre inflation.



Tyre Inflation Cage :

A must for Tyre Workshops and Vehicle Garages for safely inflating the tyres and avoiding any accidents that may be caused due to tire explosion. It ensures a safer environment for the workers.

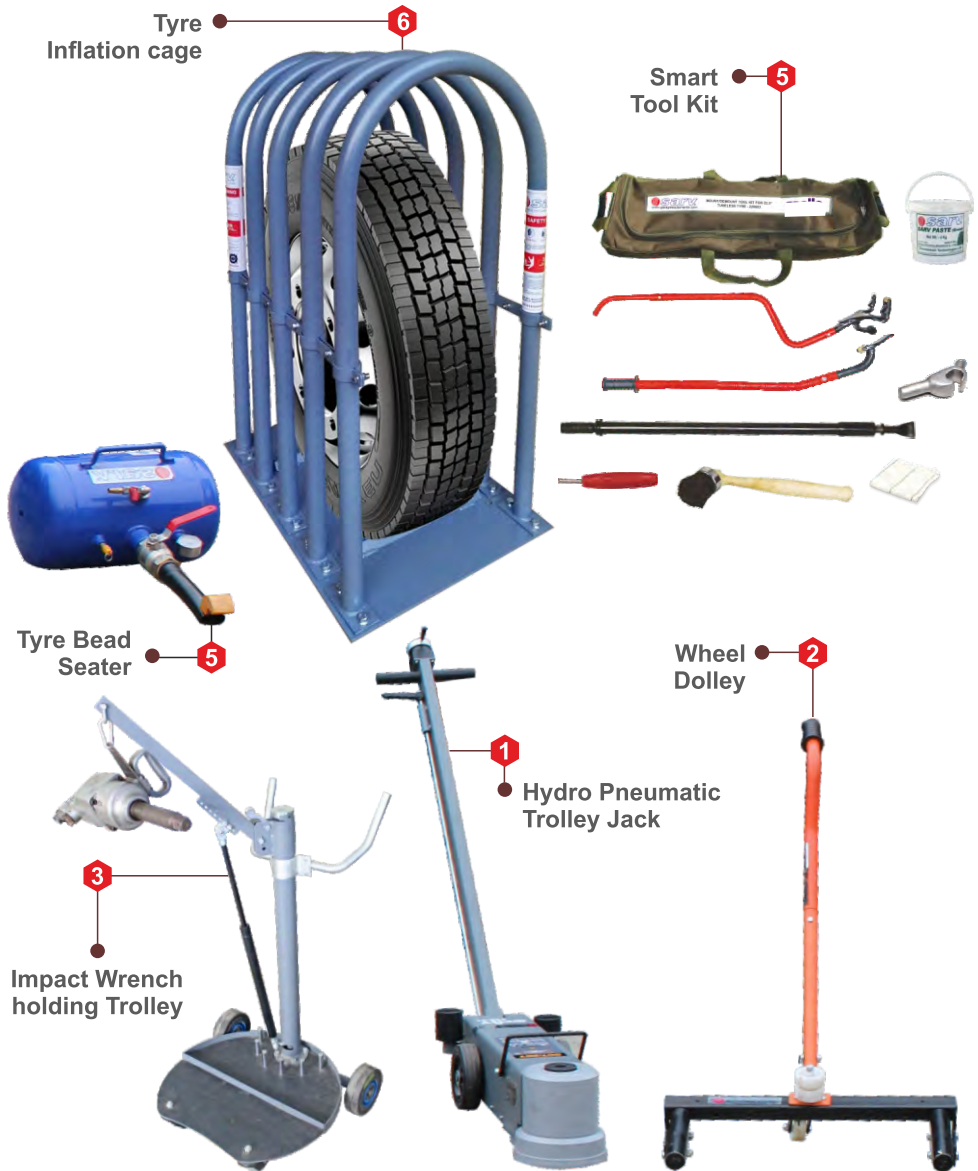

CHANGE YOUR WHEEL



Hydro Pneumatic Jack

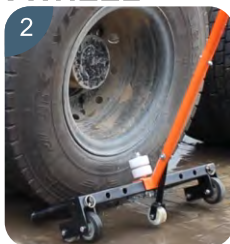

Wheel Dolly

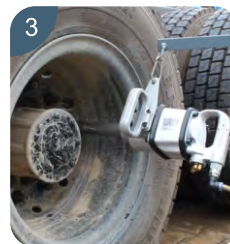

Impact Wrench Trolley



Smart Tool kit - 220603



Tyre Bead Seater

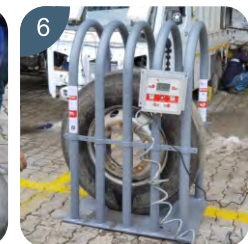

Tyre Inflation Cage



STL-BSRP10 Brake Shoe Riveting Machine | sarv

Unique Features :

Sarv riveting machine can be used for riveting of Brake linings, used in motor vehicles with the help a tubular rivets : Steel, Brass Copper or full-aluminium rivets. It is supplied with air servomotor as pneumatic drive controllable with pedal.

Additional Features

- Portable machine with optional stand
- Lathe clutch plate for riveting and de-riveting
- Pneumatically operated

* Stand Optional

Technical Data	
Recommended Pressure	6 Bar -8 Bar
Effective Force	5.5T @ 6 Bar
Riveting Size	5 -10 mm
De-riveting Size	5 -12 mm
Stroke Of Riveting Header	36 mm
Overall Length	475 mm
Overall Width	345 mm
Overall Height	550 mm
Weight	65 kg
Adjustable Anvil Height	40 mm (Max)



Magnetic Nail Lifter Trolley

SMNL150 Magnetic Nail Lifter Trolley | sarv

for Trucks & Buses

Unique Features :

- Used for quick Clearing of dangerous ferrous scrap metals which include iron chips, shavings, nails, nuts, screws, tacks, barbed wire and staples etc.
- Easy To Use Hand Held Trolley
- Wheels With Double Ball Bearing
- Discharge By Creating Gap Between Bottom Plate & Magnet
- Over All M/c Dimensions: 600 X 150mm
- Ferro Magnet Size: 400 X 100mm

Technical Data	
Magnet size(LxWxH)	18"X3"X11"
Total length	22" Inch
Total height	6" Inch
Handle total height from floor	34" Inch
Handle total height without floor	28" Inch

STBC06N

Heavy duty Battery Charger | sarv
for Cars

Unique Features

- Over Heat Protection.
- Over Load / Under Load Protection.
- Reverse Polarity Protection.
- Short Ckt. Protection.
- Ampere / Voltage Meters & Gauges
- Charging Cables Set With Suitable Connectors.



BENCH TYPE

Technical Data	
Max. Current	20 Amps
Output Voltage	12 – 72V (Up to 80V Adjustable)
Transformer	Air Cooled
Nos. of Batteries	Suitable For Charging 6 Batteries of 12V – 180AH At A Time
Input Main Supply	AC Single Phase 230 V

SAFETIES :



Reverse Polarity Protection.



Over Current Protection.



Electronic Fuse (Resettable).

ST-GP15

Portable Grease Pumps | sarv

for Trucks, Buses and Cars

Unique Features :

- These are ideal for use in industry, workshop, farm, construction or as part of the Mobile Grease System.
- Portable grease pump with build-in 15kg grease bucket.



BGRP/50

Air Operated Grease Ratio Pumps 50:1

for Trucks & Buses

Unique Features :

- World-class industrial high pressure grease pumps with guaranteed performance & hassle free operation.
- Pump dispenses grease at pressure upto 50 times the air inlet pressure.
- Designed to work in tough conditions-
- These are ideal for use in industry, workshop, farm construction or as part of the Mobile Grease System



V-12/16

Bucket Oil Pumps | sarv

for Trucks & Buses

Unique Features :

- Portable oil pumps designed for dispensing transmission differentials & heavier oils.
- Pump with variable handle setting for use with media of different viscosities.
- Includes 48" / 4' PVC hose with nozzle
- Includes steel drum (12 litre or 16 litre capacity) with a choice of with or without wheels



STL-RHP

Rotary Hand Pump | sarv

for Trucks & Buses

Unique Features :

- Most popularly used pump for general purpose lubrication on farms, automotive, workshops & construction sites.
- Pump features a dual directional operation that allows the pump to both empty as well as refill container.
- Rugged cast iron construction with machined vanes for better draw & smoother delivery.
- 1" pump inlet.
- Complete with 3 pc rigid suction tube for use on 50-210 litre drums.

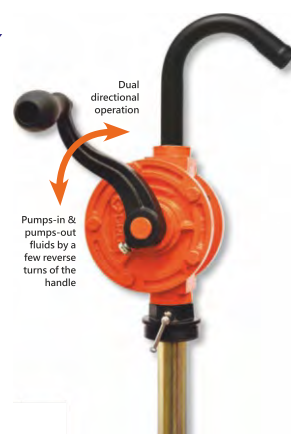

PGP-180

Trolley Mounted Grease Pump Kit | sarv

for Trucks & Buses



Unique Features :

- Designed to cater to daily bulk greasing needs at workshops requiring movable systems Includes:
- Air operated 50:1 pump suitable for 180 kg drums.
- Steel drum cover.
- Rubber lined follower plate.
- 84" high pressure grease hose.
- Grease control valve.
- Drum trolley suitable for 180 kg grease drums.

OM-300

Electric Pre-Set Oil Control Gun | sarv

for Trucks & Buses

Unique Features :

- Heavy duty oil control gun with robust aluminium construction
- Electronic preset design; works on 4 x 1.5V AA batteries
- Dual Mode: Manual & Pre-Set (dispenses set quantity of media & stops)
- Oval gear mechanism for optimum accuracy
- Adjustable outlet nozzle can be positioned for in-line or 90° dispensing
- Resettable totalizer for individual batch can be set in litres, quarts, pints & gallons



Technical Data

Flow rate	1 to 30 LPM
Inlet	1/2" BSP (F)
Accuracy	± 0.50%
Repeatability	± 0.20%
Max. working pressure	1,000 PSI (70 BAR)
Working temperature range	-5°C to 50°C
Minimum Pre. set qty.	0.10 Units
Maximum Pre. set qty.	99.9 Units
Max. resettable batch totalizer	999.9 Units
Max. non resettable batch totalizer	999999 Units
Viscosity of media dispensed	10 to 5000 cst
Resolution/ least count	0.005 litre
Water resistance	IP55

TD68 / TD90

Heavy Duty Steel Truck Drains | sarv

for Trucks & Buses

Unique Features :

- Designed for use with heavy-duty trucks, buses, RV's and other low profile automobiles where a lift drain is not suitable.
- Rugged steel construction makes it ideal for use in heavy commercial vehicles repair shops.
- Baffles* inside the reservoir prevents any oil spillage during transport.
- Available in two capacities
a. 68 litres b. 90 litres
- Both sizes available with and without pump Manual Pump discharge upto 1 litre / 5 turns



Technical Data			
Models	Description	LXWXH(mm)	Capacity
TD/68G	Gravity oil drain	1065x560x190mm	68
TD/68P	Drain with manual rotary pump	1065x560x190mm	68
TD/90BF/G	Gravity oil drain	1215x750x212mm	90
TD/90BF/P	Drain with manual rotary pump	1215x750x212mm	90

STL-ODP5

Oil Pump Kits | sarv

for Trucks & Buses

Unique Features :

- Manufactured from heavy gauge 4 mm thick steel sheet for increased strength & durability.
- 3" (75 mm) ground clearance for smooth movement over uneven surfaces in workshop environment.
- 6" (150 mm) wide polyurethane front wheels with nylon rim for reduced wear & tear.

Includes:

1. Ratio Pump Assembly.
2. Hose reel.
3. Trolley.
4. Oil control Gun.
5. Filter, Regulator Combination and Lubricator with Pressure Gauge.



Technical Data	STL-ODP3	STL-ODP5
Pump Ratio	3:1	5:1
Working Pressure	30-150 PSI	30-150 PSI
Max. Air Pressure	150 PSI	150 PSI
Flow Rate at Pump Outlet	Up to 14 LPM	Up to 18 LPM
Least Count of Oil Control Gun	0.001 units	0.001 units
Accuracy of Meter	±0.5%	±0.5%
Repeatability of Meter	0.30%	0.30%
Hose	3.5m Hydraulic Hose with 1/2" ID	10m Hose Reel with 1/2" ID
Thread Type	BSP	BSP
Air Consumption of Pump	230 LPM	250 LPM

GREEN-DEF-40A

DEF Dispensing System Closed, Sealed & Secure | sarv

for Trucks & Buses

Unique Features :

DEF pump kit is designed for IBC tank, it's the best choice for filling and dispensing the DEF, the kit is Mounted with the tank, with automatic nozzle and K24 flow meter, you can dispense the DEF very easily.

Accessories :

1. 240V adblue pump
2. K24 meter
3. 3/4" automatic nozzle
4. Hose
5. IBC adaptor
6. Stainless basket

12v Pump also available on request

Technical Data	
Voltage	240V/50Hz
Power	370W
Speed	1450rpm
Flow Rate	0-30L/min
Inlet & outlet	25mm
Suction	1 m
Packing Size	40x40x30cm



AP 35 Adblue Pump	Meter (K24)	Def Automatic Shut off Nozzle (LB 325)	DEF EPDM Hose	Bracket
Flow : 35-45L/min self-priming : 3m voltage : 230V AC 50hz or 12/24V DC	Flow range : 10-120L/min Accuracy : 1% pressure : 1Mpa Connections: BSPF1" or NPT1"	Fittings : 3/4", 1", BSPF or NPT1" Flow range : 0-60L/min Max pressure: 5 bar	Dia : 19mm Material : EPDM Thickness : 4MM	With nozzle holder 2mm thickness SS304 material

FITNESS TEST LANES FOR BUSES & TRUCKS

TRUCK BRAKE TESTER | sarv

Unique Features :

- BRT Series products can not only test brake force, brake efficiency, brake imbalance and friction efficiency, but also axle load, wheel load and ovality.
- Truck brake tester can be used in garages and vehicle inspection stations.
- Together with other SARV products such as sideslip tester, speedometer, play detector, headlight tester and emission tester to compose a vehicle test lane.
- With excellent coating workmanship, the corundum roller has more than 200,000 life span.
- Equipped with self-stop function, which will stop automatically in case of overload to protect the machine.(only with SARV Control System).
- Split-type design enables the device to be applicable to different wheel track.
- Pedal Force Meter is available as an option upon requirements of some countries.
- SARV special design makes two-direction entry of 10T truck brake tester possible, which allows the vehicle to drive in from either front or rear side. For more details, please contact us directly
- The lifting function can be selected to give consideration to the detection of both cars and trucks..



Technical Data		
Item	BRT-1000	BRT-1500
Max axle load	10T	15T
Test speed	2.5km/h	2.5km/h
Brake force range	0-30KN	0-45KN
Motor	11kwx2	15kwx2
Power supply	380V/50HZ	380V/50HZ
Adhesion coefficient	0.8	0.8
Roller diameter	245mm	1200mm
Roller length	1000mm	3020x790x356mm
Dimensions (LxWxH)	1900x1024x470mm (2pcs,left and right bench)	2170X980X440mm (2pcs,left and right bench)

TRUCK SIDESLIP TESTER | sarv



Unique Features :

- SST-1000 and SST-1500 Sideslip Tester test the comprehensive degree of the deviation.
- High precise sideslip tester sensor ensures the accurate reach 0.1mm.
- Pre-check the vehicle toe-in before wheel alignment, saving your time.
- Only 5 seconds by driving through to results, Sideslip(mm).
- It can be used in garages and vehicle inspection stations, to compose as a vehicle safety test lane with Truck Brake Tester, and Speedometer.

Technical Data		
Item	SST-1000	SST-1500
Axle load	10T	15T
Test speed	5-10km/h	5-10km/h
Range	±15mmh	±15mmh
Dimension (LxWxH)	1150x860x105mm	1400x1170x140mm

SPEEDOMETER TESTER | sarv

Technical Data			
Item	SSP-300	SSP-1000	SSP-1500
Axle load	3T	10T	15T
Air pressure	0.8 Mpa	0.8 Mpa	0.8Mpa
Power supply	220V	220V	220V
Testing range	0-120km/h	0-120km/h	0-120km/h
Roller diameter	Φ190x750mm	Φ190x1000mm	Φ190x1200mm
Dimension (LxWxH)	2500x750x356mm	3020x790x356mm	3420x790x356mm

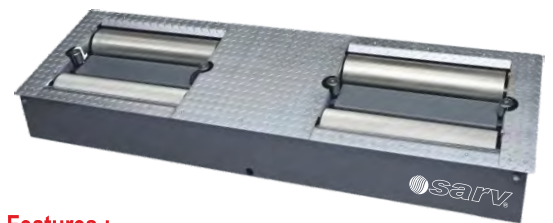

Unique Features :

- Curved roller of it has high friction coefficient and long life time.
- Speed-limited lift air, only lifting when wheels no running to ensure the safety during the testing and drive vehicle off the bench.
- Security device in case of the rim and tyre wear during high speed testing
- Accessory 3T cover ensure the installed bench area like the smooth earth



Play Detector

Control System



HEAD LIGHT ALIGNER | sarv

CAMERA ON BOARD EALIGHT BEAM SETTER

Technical Data

Display Board

Color TFT Display Touchscreen: display 5,7" 320x240

Camera Board

CMOS Camera 640x480 VGA - dimensions PIXEL 6.0 x 6.0µm

Ambient conditions

Property Working temperature Humidity Storage and transportation	Value/Range +5°C -+45°C 20%-80%
Property Temperature Humidity Dimensions and weight	Value/Range -25°C-45°C/-13°F-113°F 30%-60%
Property Dimensions Weight Measuring range	Value/Range (W x D x H) 660 x 695 x 1780 mm 35 kg (66lb)
Property Top and bottom alignment Right and left alignment: Luminosity Illuminance Height of optical center point from ground level Power supply (internal battery) Input voltage of battery charger Measurement accuracy	Value/Range 0-+/-600mm/10m (0; +/-6 %) 0-1000mm/10m (0;+/-10%) 0-240lx (0-150.000cd) 0. 150.000 lx 240-1450 mm 12V 100-240 V, 50/60Hz
Property Intensity Vertical axis deviation Horizontal axis deviation	Value/Range +/-5% end of scale +/-0,1% +/-0,2%



Standard configuration

Visor	= Mirror
Column	= extruded aluminium
Optical box	= Injection molded box complete with color TFT 5.7" touchscreen Displaycomplete with internal level and cross reference laser, fresnell lens
Base	= 3 wheels base complete with levelling adjustment

Available options

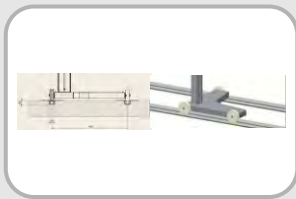

High Precision rail system to be recessed for a proper level led working surface



Single or double rail kit for a designed working area already levelled



Laser visor



Height sensor for an electronic reading of the beam height

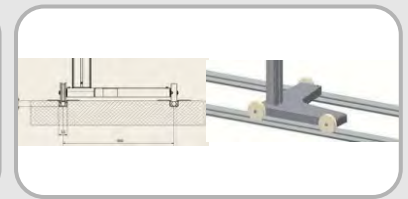

Electronic board is equipped with a microchip accelerometer recording the 0 position. Once HBT is placed on the working area, microchip is detecting floor slope and sending data to the main electronic board. Such a correction is recorded and calculated before test results will be displayed. Accelerometer reference axis: X, Y, Z Accelerometer accuracy: 0.057° (1 cm/10 meters)



Printer on board



Bluetooth Module for PC transmission data



WiFi Module

Headlight PC SW

PC sw handling all test data for:

- a) Recording;
- b) Databasecreation

PP3 POWER PROBE

CIRCUIT TESTER

Digital Voltmeter 12-24V

Unique Features

- Voltmeter
- Supplies power and ground
- Digital Voltmeter with min/max voltage capturing
- Voltage & Polarity testing
- Continuity testing
- Powers up components
- Light and relay tester
- Checking for bad ground contacts
- Red/Green Indicator & Audio Tone



The Power Probe 3 is a Digital Voltmeter that works off of 12-24 volt sources with the ability to apply power and ground. Using an Auxiliary Ground cable, the user can simultaneously supply Battery Voltage, and ground to test components or to simply test for continuity

Technical Specifications

- DC 0 to +70V +1 Digit • P-P 0 to +70V
- The frequency response of tone pass through**
- 10Hz to greater than 10 kHz
- PP Display**
- 15 Hz Square Wave • 35 Hz Sine Wave
- Power Probe Mode – Continuity to ground**
- First level – Display is enabled less than 20 K Ω
- The second level – Green LED is enabled less than 600 Ω
- & +Peak Detector Response**
- Single event capture less than 200ms pulse width
- Repetitive events less than 1ms pulse width
- Peak to Peak Mode**
- 0 to + 70 + 1 Digit • 4Hz to over 500kHz Square Wave input
- 4Hz to over 250kHz Sine Wave input
- The threshold for PPAC/Audible passthrough
- Circuit Breaker 8 amp thermal response – Manual rese

ECT3000 POWER PROBE

CIRCUIT TRACER & SHORT FINDER

Unique Features

- Locate short circuits without unnecessarily removing plastic panels, molding, and carpet.
- Isolate your circuit
- Trace wires to see where they lead
- Find open circuits, switches or breaks in wires
- Trace and locate the cause of a severe battery drain
- Test and find intermittent conditions
- Check continuity with the assistance of the Power Probe III, IV, or Hook

ECT3000 Contents (Stand alone packaging)

- ECT3000 Transmitter
- ECT3000 Receiver
- Universal 4mm Adapter
- Alligator Clip
- AAA Batteries
- Dimensions:
Color Box : 188 x 280 x 50 mm
Carton Box : 400 x 290 x 315 mm
• Amount / Box : 10 PC



The ECT3000 gives you a quick solution and allows you to test automotive circuit problem. It quickly helps you locate the wiring shorts and open circuit. Both tools consist of 2 main components: An Intelligent transmitter and a Intelligent receiver along with a set of connection adapters

Technical Specifications

- TRANSMITTER**
- Min Operating Voltage: 6 VDC
 - Max Operating Voltage: 48 VDC
 - Working Current: <200mA
 - Working Frequency: 4KHz
 - Max Operating Temp: 50 C°
 - Max Storage Temp: 70 C°
 - Max Operating Relative humidity: 80% (Non-condensation)
 - Max Storage Relative humidity: 80% (Non-condensation)
 - Altitude: <2000m
- RECEIVER**
- Power Supply: 2 X 1.5V AAA
 - Working Current: When not signal be detected <15mA
 - Power Consumption When Power Off: <10uA
 - Max Operating Temp: 50 C°
 - Max Storage Temp: 70 C°
 - Max Operating Relative humidity: 80% (Non-condensation)
 - Max Storage Relative humidity: 80% (Non-condensation)
 - Altitude: <2000m

STL-ACSEMI-20E

A/C Refrigerant Work Station | sarv

for Cars & LCV's

Unique Features

- LCD Monochrome Display.
- Filter in recovery line to eliminate humidity & acidity.
- Manual air purge from refrigerant tank.
- Auto calibration mode.
- shock proof protection for load cells.

Technical Data	STL-ACM-SEMI
Operating Mode	Semi-Auto
Power Supply	220V±10% 50/60Hz
Cylinder Capacity	13.6Kg / 20kg
Max. Refrigerant	10Kg
Recovery Rate	95%
Vapor Recovery Speed	300g/min
Liquid Recovery Speed	200g/min
Charge Speed	800g/min
Vacuum Speed	3600L/hour
Dry Filter	350ml
Load Cell Accuracy	±10g



ST-IW03

3/4" Drive
SQ. Impact Wrench | 
 for Cars & LCV's



Technical Data	
Air pressure	6-10 kg/cm2
Air inlet	3/8"
Free Speed	6000 r.p.m
Square Head	3/4"
Blow Structure	Twin Hammer
Max. Torsion	1350 N.m
Disassembling Ability	32mm
Net Weight	5.2Kg

ST-5300

1/2" Drive
SQ. Impact Wrench | 
 for Cars & LCV's



Technical Data	
Air pressure	6-8kg/cm2
Air inlet	1/4"
Free speed	8500r.p.m
Square head	1/2"
Blow structure	Twin hammer structure
Max torsion	1200N.m
Disassembling ability	24mm
Spindle length	1"
Net weight	3.0kg

TSW-840SL | TSW-842P

Pneumatic 1 inch
Impact Wrenches | 
 for Trucks & Buses



- Ergonomic design.
- Compact.
- Built-in power regulator.
- Single forward and reverse button.
- Positive action trigger.

Technical Data	TSW-840SL	TSW-842P
Max torque	2300 nm	2500 nm
working torque	830-2000 nm	1000-2200 nm
Capacity	M40 bolt size	M41 bolt size
Free speed	4400 rpm	4700 rpm
Weight	12.1 kg	10.9 kg
Hammer mechanism	Pin hammer	Pin hammer
Air consumption	0.75 m3/min	0.75 m3/min
Air consumption	26.5 c.f.m	26.5 c.f.m

ST-5068

1" Drive
SQ. Impact Wrench | 
 for Trucks & Buses



Technical Data	
Air pressure	8-10kg/cm2
Air inlet	1/4"
Free speed	3500r.p.m
Square head	1"
Blow structure	A single hammer without pin
Max torsion	3500N.m
Disassembling ability	46mm
Spindle length	8"
	16.8kg

ST-680B

1" Drive
SQ. Impact Wrench | 
 for Trucks & Buses



Technical Data	
Air pressure	6-8kg/cm2
Air inlet	1/2"
Free speed	4000r.p.m
Square head	1"
Blow structure	Twin hammer structure
Max torsion	3100N.m
Disassembling ability	36mm
Spindle length	1"
Net weight	3.0kg



220412



220514



220614

330002



220134



2200130



220500



220415



D0015

1 220603 SMART TOOL KIT



221414



221514



220134

330002



220513



220415



D0015



2200130

2 220905 TUBELESS TYRE MOUNT DEMOUNT TOOL KIT FOR 17.5" TYRES



220914



221014



221014



220008



220003



330002

3 220303 RING REMOVAL/FITTING TOOL KIT

1 Tubeless Tyre Mount/Demount Smart T

Weight:
29.385kg

Code No.
220603

The Kit contains the following items:

Tool:	Qty:	Weight:	Code No.
• Bag with Wheels (optional)	1 No.	4.600kg	220412
• Mounting Lever	1 No.	2.950kg	220514
• Demounting Lever	1 No.	10.100kg	220614
• Impact Bead Breaker	1 No.	10.500kg	220134
• Bead Holding Tool	1 No.	770gms	220500
• Valve Core Screw Driver	1 No.	25gms	330002
• Sarv Paste (Economy)	1 No.	1.000kg	2200130
• Brush for Truck Tyre	1 No.	150gms	220415
• Duster	1 No.	15gms	D0015

Use : Mounts all type of tubeless tyres 20" to 24.5". Demounts tyre in 8 seconds and remounts in 20 seconds.



2 Tubeless Tyre Mount/Demount Tool Kit for 17.5" Tyre

Weight:
21.600kg

Code No.
220905

The Kit contains the following items:

Tool:	Qty:	Weight:	Code No.
• Mounting Lever	1 No.	2.200kg	221514
• Demounting Lever	1 No.	6.500kg	221414
• Impact Bead Breaker	1 No.	10.500kg	220134
• Bead Holding Tool	1 No.	250gms	220513
• Valve Core Screw Driver	1 No.	25gms	330002
• Sarv Paste (Economy)	1 No.	1.000kg	2200130
• Brush for Truck Tyre	1 No.	150gms	220415
• Duster	1 No.	15gms	D0015

Use : Specifically designed to mount/demount 17.5" tyres without damaging the tyre bead and rim.



3 Rim Lock Ring Fitting/ Removal Tool Kit (For TubeType Tyres)

Weight:
18.215kg

Code No.
220303

The Kit contains the following items:

Tool:	Qty:	Weight:	Code No.
• Ring Removal Tool	1 No.	3.500kg	220914
• Ring Fitting Tool	2 No.	2.950kg	221014
• Tyre Lever 600mm	2 No.	930gms	220008
• Tyre Lever with Crank End	1 No.	1.360kg	220003
• Valve Core Screw Driver	1 No.	25gms	330002





4 220503 REGULAR TOOL KIT



5 220403 STANDARD TOOL KIT



6 2206953 TUBELESS TYRE MOUNT DEMOUNT COMBO TOOL KIT

4 Tubeless Tyre Mount/Demount Regular Tool Kit

Weight: 21.435kg
Code No. 220503

The Kit contains the following items:

Tool:	Qty:	Weight:	Code No.
Mounting lever	1 No.	2.600kg	220414
Demounting Lever	1 No.	6.500kg	220314
Impact Bead Breaker	1 No.	10.500kg	220134
Bead Holding Tool	1 No.	770gms	220500
Valve Core Screw Driver	1 No.	25gms	330002
Sarv Paste (Economy)	1 No.	1.000kg	2200130
Brush for Truck Tyre	1 No.	150gms	220415
Duster	1 No.	15gms	D0015

Use : Mounts all type of tubeless tyres 20" to 24.5". Demounts tyre in 8 seconds and remounts in 20 seconds. Works on standard and super single duplex tyres.



5 Tubeless Tyre Mount/Demount Standard Tool Kit

Weight: 22.170kg
Code No. 220403

The Kit contains the following items:

Tool:	Qty:	Weight:	Code No.
Bag with Wheels (optional)	1 No.	4.600kg	220412
Tyre Lever	2 No.	1.950kg	220004
Tyre Lever	1 No.	1.630kg	220184
Impact Bead Breaker	1 No.	10.500kg	220134
Bead Holding Tool	1 No.	350gms	220400
Valve Core Screw Driver	1 No.	25gms	330002
Sarv Paste (Economy)	1 No.	1.000kg	2200130
Brush for Truck Tyre	1 No.	150gms	220415
Duster	1 No.	15gms	D0015

Use : Mounts / Demounts all types of tubeless tyres 17.5" to 24.5".



6 Tubeless Tyre Mount Demount Combo Tool Kit

Weight: 40.410kg
Code No. 2206953

The Kit contains the following items:

Tool:	Qty:	Weight:	Code No.
Bag with Wheels (optional)	1 No.	4.600kg	220412
Mounting Lever	1 No.	2.950kg	220514
Demounting Lever	1 No.	10.100kg	220614
Mounting Lever	1 No.	2.200kg	221514
Demounting Lever	1 No.	6.500kg	221414
Bead Holding Tool	1 No.	250gms	220513
Sarv Paste (Economy)	1 No.	1.000kg	2200130
Brush for Truck Tyre	1 No.	150gms	220415
Duster	1 No.	15gms	D0015
Ring Removal Tool	1 No.	3.500kg	220914
Ring Fitting Tool	2 No.	2.950kg	221014
Tyre Lever 600mm	2 No.	930gms	220008
Tyre Lever with Crank End	1 No.	1.360kg	220003
Valve Core Screw Driver	1 No.	25gms	330002

Use : Tubeless tyres 22.5", 17.5" and Tube type tyres.





7 220804 COMBI OTR TYRE BEAD BREAKER KIT



8 220903 GIANT OTR BEAD BREAKER KIT

7 COMBI OTR Tyre Bead Breaker Kit
Weight: 30.500 Kg
Code No. 220804

The Kit contains the following items:

Tool:	Qty:	Weight:	Code No.
• Combi Bead Breaker	1 No.	–	220804A
• Air Hydraulic Pump (10,000 psi)	1 No.	–	220804B
• 8' Hydraulic Hose	1 No.	--	220804C

Use : Works on single, 2 and 3 piece 25" wheels. The tool clamps hydraulically to the wheels and then breaks bead with 11 tons of force. 3.75" (9.5cm) stroke length. Used with 10,000 psi (700bar) air/hydraulic pump.



8 Giant OTR Bead Breaker Kit
Weight: 21.500 Kg
Code No. 220903

The Kit contains the following items:

Tool:	Qty:	Weight:	Code No.
• OTR Giant Tire Bead Breaker	1 No.	–	220903A
• Air Hydraulic Pump (10,000 psi)	1 No.	–	220804B
• 8' Hydraulic Hose	1 No.	--	220804C

Use : Most popular tool for breaking beads on earthmover tires, sizes 25"-51". Works on 5 piece wheels with bead loosening pockets. 4 1/4" (10.8 cm) stroke ram.



1 220415



2 221115

1 Special Brush for Tyres with Wooden Handle for Trucks & Earthmovers
Size (Handle): 300mm long
Dia. 50mm
Weight: 150gms
Code No. 220415

Use : Used to lubricate tire beads when mounting or removing tyres.



2 Special Brush for Tyres with Wooden Handle
Size (Handle): 340mm long
Dia: 50mm
Weight: 68gms
Code No. 221115

Use : Used to lubricate tire beads when mounting or removing tyres.



3 2200120

3 2200420

3 Sarv Paste (White)
Colour: Yellow
Weight: 1kg
Code No. 2200120
Weight: 4kg
Code No. 2200420

Use : Quick drying, non greasy tyre paste. Used for lubricating tyre beads in mounting & demounting operations.



4 2200130

4 2200430

4 2200530

4 Sarv Paste (Economy)
Colour: White
Weight: 1kg
Code No. 2200130
White 4kg
Code No. 2200430
White 5kg
Code No. 2200530

Use : Quick drying, non greasy tyre paste. Used for lubricating tyre beads in mounting & demounting operations.



5 2200440

5 Tyre Grease (From Michelin, France)
Colour: Brown
Weight: 4kg
Code No. 2200440

Use : Quick drying, non greasy tyre paste. Used for lubricating tyre beads in mounting & demounting operations.

**IN HOUSE
MANUFACTURING**



1 2200117



2 2200217



2 2200517



3 2200317



4 2200417



5 2200137



6 550005



7 550005BL

1 Tyre Tread Depth Gauge (Plastic)

Size:
0 - 30mm

Weight:
30gms

Code No.
2200117

2 Tyre Tread Depth Gauge (Stainless Steel)

Size:
For Passenger Car tyre 0 - 50mm
For Truck tyre 0 - 90mm

Weight:
30gms
85gms

Code No.
2200217
2200517

3 OTR Tread Depth Gauge (Aluminum)

Size:
0 -150mm /
0-192 (32 NDS)

Weight:
170gms

Code No.
2200317

Use : For measurement of Earthmover tyre tread depth. Supplied with case. Easy readability due to Glass lens.

4 OTR Tread Depth Gauge (Acrylic Plastic)

Size:
0-160mm /
0-192 (32 NDS)

Weight:
55gms

Code No.
2200417

Use : For measurement of Earthmover tyre tread depth. Supplied with case.



5 Digital Depth Gauge

Size:
0 - 50mm

Weight:
35gms

Code No.
2200137

Use : Calibrated in mm. Good for Passenger Car tyre. Used for measuring tread depth.

6 Tool to Cancel Tyre Tread

Weight:
110gms

Code No.
550005

Material : Blades are made from Special Steel.

Use : Used for cleaning the tyre by cancelling the extra tyre treads.



7 Blade for Tool to Cancel Tyre Tread

Size:
0 - 50mm

Weight:
2gms

Code No.
550005BL

Use : Used as an accessory for 550005.

**IN HOUSE
MANUFACTURING**



8 224222



8 224222R



9 224217



9 224224



10 665400 Manual Wrench Set



11 220313 Tyre Bead Seater/Blaster

8 Pump Ring Rigid for Tubeless Truck Tyre

Size: 22.5" **Weight:** 11.000kg **Code No.** 224222

Use : Provides safe seating of tubeless tyres during inflation. Specifically useful for deformed or bent rims where air escapes during inflation. Forms a seal around the rim and automatically comes out upon complete inflation.

Rubber Ring for Pump Ring Rigid

Weight: 3.500kg **Code No.** 224222R

Use : Used inside rigid pump ring. Provides an anti slippery firm seating of the pump ring on the rim.



9 Pump Ring Flexible for LCV and HCV Tubeless Tyre

Sectional Dia: 25mm **Size:** 17.5" **Weight:** 750gms **Code No.** 224217
25mm 22.5" to 24.5" 1.000kg **224224**

Use : Used for sealing the tyre beads of the rims.



10 Manual Wheel Nut Opening Wrench Set

Sockets: 27, 32 mm **Size:** 1" **Sockets:** 27, 32 mm **Code No.** 665400

Material : Alloy.

Use : Opens Truck / Bus Nuts with ease. Portable and safe to use. Rests between two nuts for leverage.



11 Tyre Bead Seater/Blaster

Code No. 220313

Use : Seats beads on all tyres upto 24.5" truck tyres. Includes easy carry handle for portability. Included mounting feet makes storing the unit easy and helps protect the barrel assembly from damage Operates on standard shop air: Max 120 PSI



**IN HOUSE
MANUFACTURING**



12 224430



12 224432



12 224433



12 224436



12 224438



12 224440



13 224232



13 224233



13 224332



13 224333

12 WHEEL PROTECT[®] Loose Wheel Nut Indicator

Size:	Code No.	Size:	Weight:	Code No.
17mm	224417	30mm	2gms	224430
19mm	224419	32mm	2gms	224432
21mm	224421	33mm	2gms	224433
24mm	224424	36mm	2gms	224436
26mm	224426	38mm	2gms	224438
27mm	224427	40mm	2gms	224440
		41mm	2gms	224441

Material : Special Durable Plastic.

Colour : Fluorescent Yellow, Red, Pink, Green, Orange.

Note : Customized colour can be provided for large orders.

Before: Loose wheel nut indicators securely set over wheel nuts pointing towards each other. Tyre is safe for travel.



After: Link broken due to loose nuts. Change in direction indicate the loosening of nut. Loose Nuts need to be tightened before tyre can be made safe for travelling.

13 Dust Cap & Loose Wheel Nut Indicator

Type:	Size:	Weight:	Code No.
Upper arrow	32mm	17gms	224232
Upper arrow	33mm	17gms	224233
Bottom arrow	32mm	17gms	224332
Bottom arrow	33mm	17gms	224333

Material : Special Durable Plastic.

Colour : Green, Red, Yellow, Pink.

Note : Customized colour can be provided for large orders.

Before: Loose wheel nut indicators securely set over wheel nuts pointing towards each other. Tyre is safe for travel.



After: Link broken due to loose nuts. Change in direction indicate the loosening of nut. Loose Nuts need to be tightened before tyre can be made safe for travelling.

 IN HOUSE
MANUFACTURING



1 Valve Core Screw Driver standard single ended 1" stem length

Colour: Red **Weight:** 25gms **Code No.** 330002

Material : Carbon Steel and Plastic handle.
Use : Removing & fixing valve cores.

2 Valve Core Screw Driver standard single ended 1" stem length

Colour: Red **Weight:** 20gms **Code No.** 3300014

Material : Carbon Steel and Plastic handle.
Use : Removing & fixing valve core VG5.

3 Valve Core Screw Driver 2" Stem Length with Torque

Weight: 40gms **Code No.** 3300414

Torque : Pre-set tightening torque 0.4 Nm.
Material : Carbon Steel & Plastic handle. Metal part is Nickel Chrome Plated.
Use : Prevents over screwing of the core while removing & fixing.

4 Valve Core Screw Driver double ended 1" stem length (VG5/VG8)

Colour: Red **Weight:** 35gms **Code No.** 3300012

Material : Carbon Steel and Plastic handle.
Use : Removing & fixing valve cores, VG5 from one end and VG8 from the other end.

5 Valve Core Screw Driver for Truck/Bus Tyres

Weight: 100gms **Code No.** 3300111

Use : For removal and fixing of truck/bus tyre valve core and caps from each side respectively.

6 Valve Cap Screw Driver For OTR Tyres

Weight: 120gms **Code No.** 3300641

Material : Special Steel.

7 Ventifix Plastic

Colour: Green **Weight:** 75gms **Code No.** 330003
Blue **Weight:** 75gms **Code No.** 330003BLU

Material : Polyamide-6 for imparting super bending strength to the lever.
Finish : All metal parts are Nickel Chrome Plated.
Use : For mounting Rubber snap-in valves on Passenger Car. Protects light metal alloy rims from scratch.

8 Flexible Valve Extensions

Size **Code No.**
85mm 550006
Available in 3 sizes 115mm
125mm

Use : Used as flexible valve extension for extension for inflating the tyres.



9 Flexible Valve Extensions for OTR Tyre Valves

Code No. 551117

Use : Used as flexible valve extension for OTR tyre valves.

PRESSURE GAUGE

BEST SELLER



1 554008 | 



2 556008

BEST SELLER



3 551008 | 

BEST SELLER



4 551208 | 

INFLATOR GAUGE

BEST SELLER



5 559008 | 



6 551408



7 551508



8 551508DF



Pressure Gauge with Deflator

9 557008

1 Truck Tyre Pressure Gauge (EURODAIRA) With Dual Foot Chuck for Standard Bore Valves (From Wonder Italy)

Range: (0.7-12) Bar (10-170)psi **Weight:** 286gms **Code No.** 554008

Use : For Passenger Car, Motorcycle and Scooter.

2 Pressure Gauge for checking the pressure

Range: (220psi / 15kg / 1500kpa) **Weight:** 286gms **Code No.** 556008

3 Tyre Pressure Gauge (EURODIARA) (From Schrader, France)

Range: Dual calibrated: (0.7-12) Bar and (10-170) psi. **Weight:** 170gms **Code No.** 551008

Note : 1.5 metre hose length.

4 Tyre Pressure Gauge (EURODIARA) (From Schrader, France)

Range: Dual calibrated: (0.7-12) Bar and (10-170) psi. **Weight:** 350gms **Code No.** 5508

Use : Use with small and big bores. Has two adjustable valve openings.

5 Dial type Tyre Inflator Gauge (EURODIANU) (From Schrader, France)

Range: Dual calibrated: (0.7-11) Bar and (10-160) psi. **Weight:** 680gms **Code No.** 559008

Note : 1.5 metre hose length. Protective rubber covers around the gauge body.

6 Tyre Inflator Gauge (from Mastair)

Range: Dual calibrated: (0.7-12) Bar and (10-170) psi. **Weight:** 650gms **Code No.** 551408

7 Digital Tyre Inflator

Range: Dual calibrated: (0.7-12) Bar and (10-170) psi. **Weight:** 750gms **Code No.** 551508

8 Digital Tyre Inflator, Dual Foot

Range: Dual calibrated: (0.34-12) Bar and (5-170) psi. **Weight:** 645gms **Code No.** 551508DF

Note : Hose length 450mm.

9 Pressure Gauge with Deflator for checking Tyre pressure & Deflation

Range: (220psi / 15kg / 1500kpa) **Weight:** 239gms **Code No.** 557008



10 555008

10 Inflator Gauge			
Range:	(0.7-12) Bar(10-174)psi	Weight:	350gms
		Code No.	555008

11 Air Inflation Nozzle			
Size:	Air nipple 6 mm	Weight:	30gms
		Code No.	550011

Use : Used in Passenger cars and trucks during inflation. Is connected to the valve.



11 550011

TYRE REPAIR TOOLS & KITS



1 443831



2 443861



3 440004



4 440005

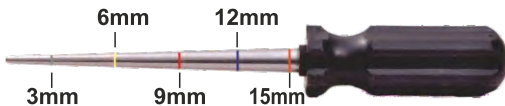

5 4400041



6 4400021

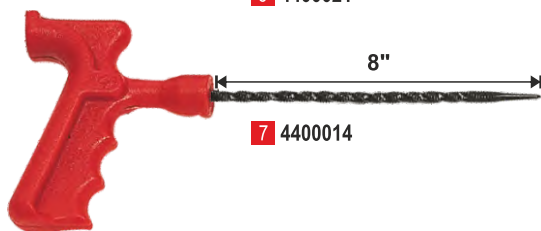

7 4400014

1 Sticher Serrated Wooden Handle			
Thickness:	3mm	Dia:	38mm
		Weight:	135gms
		Code No.	443831

2 Sticher Serrated Wooden Handle			
Thickness:	6mm	Dia:	38mm
		Weight:	160gms
		Code No.	443861

3 Flexible Skiving Knife			
		Weight:	50gms
		Code No.	440004

4 Hoe Style Inner Liner Scraper			
Colour:	Blue	Weight:	120gms
		Code No.	440005

Use : For cleaning the inner liners for both puncture and section repair prior to buffing.



5 Tyre Injury Measuring Tool			
		Weight:	95gms
		Code No.	4400041

Use : A special tool used for measuring tyre injury varying from 3mm to 15mm.

6 Tyre Probe			
Handle:	Wooden	Size:	100mm long
		Weight:	110gms
		Code No.	4400021

Use : For verifying damages, course of injuries and removing small foreign objects from the tyre tread.

7 Truck Rasp in Pistol Grip Handle			
Colour:	Red	Size:	8"
		Weight:	100gms
		Code No.	4400014

**IN HOUSE
MANUFACTURING**

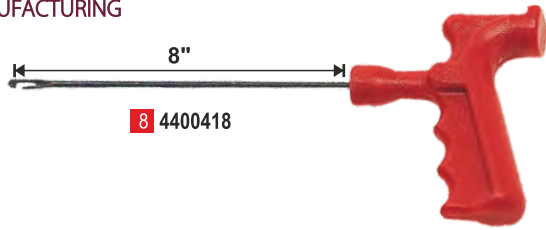

8 4400418



9 4400017



9 4400917



9 4400617



9 4401917



9 4401617



9 4401017



9 4400817



9 4401317



9 4401817



10 660005 High Speed Buffer Kit

8 Side Split Needle in Pistol Grip Handle

Colour: Red
Size: 8"
Weight: 110gms
Code No. 4400418



9 Angular Milling Cutter (High Speed Steel)

Blade Length :	Total Length:	Dia:	Weight:	Code No.
30mm	90mm	6mm	16gms	4400017
45mm	80mm	6mm	18gms	4400617
45mm	75mm	6mm	16gms	4401617
50mm	110mm	8mm	40gms	4400817
60mm	110mm	8mm	40gms	4401817
40mm	110mm	9mm	45gms	4400917
50mm	110mm	9mm	45gms	4401917
64mm	115mm	10mm	55gms	4401017
72mm	120mm	13mm	95gms	4401317

Use : For the precise injury preparation on radial and cross-ply tyres.

10 High Speed Buffer / Skiver Kit

Weight: 1.200kg
Code No. 660005

The Kit contains the following items:

Tool:	Qty:
Air die grinder	1 No.
• 1/4"/6mm Mounted grinding stones	5 No.
• 1/8"/3mm Mounted grinding stones	5 No.
• Hand Wrenches	2 No.
• Air Nipple	1 No.
• 3mm 1/8" collet	1 No.
• Blow mold case	1 No.

11 SARV HCV Seal KIT (Mushroom Type Tubeless Tyre Repair Kit)

Weight: 2.350kg
Code No. 440097

The Kit contains the following items:

Tool:	Qty:	Code No.
• Bag	1 No.	220302
• Sarv Vulcanising Fluid 250ml	1 No.	SC703
• Mushroom patch 6mm	5 No.	440227
• Mushroom patch 8mm	5 No.	440327
• Angular Milling Cutter 6mm	1 No.	4400617
• Angular Milling Cutter 8mm	1 No.	4401817
• Spherical Rasp	1 No.	440627
• Tyre Injury Measuring Tool	1 No.	4400041
• Special Sticher for Mushroom Kit	1 No.	443861
• Chalk for Marking	1 No.	YCH01
• Knife to cut the extra patches	1 No.	44CK07
• Combination Plier	1 No.	CP1
• Hoe Style Inner Liner Scrapper	1 No.	440005BK
• Wire Brush	1 No.	WB2
• Electric Drill Machine (13mm)	1 No.	85022-13



WB2



220302



SC703



440327



4400617



4401817



440227



443861



440627



4400041



YCH01



CP1



440005BK



44CK07

11 440097 SARV HCV SEAL KIT

S250T

Air Operated Truck Tyre Spreader (With Lying Base) | sarv

Unique Features :

- The air powered tyre spreader (with laying Base) is designed for fix, spread and lift when repairing truck tyres. The available operations include tyre inspection, cutting, buffing, dust suctioning, inserting tubes and patching.
- The wider platform offers a more stable work surface. The adjustable light increases visibility inside the tyre. All makes the repairing works quick and convenient.

Technical Data	
Voltage	220/110V 50/60V
Air pressure	8-12kgs/cm ²
Apply to tyre	Max. 18R/22.5"
Net weight	127kgs
Gross weight	160kgs



S450T

Air Operated Truck Tyre Test Tank | sarv

Unique Features :

- Air operated truck tyre test tank (with lift).
- Efficient, safe and convenient testing of car, truck, tractor and EM tubeless tyre as well as inner tubes.
- The mobile lift which can lift pallets up to 600kg (with optional forks) can be detached from the test tank.
- With Built-in safety Features.

Technical Data	
Air pressure	6-12kgs/cm ²
Max. wheel diameter	1350mm
Net weight	245kgs
Gross weight	280kgs

4400620

Tyre Bench Spreader | sarv

Technical Data	
Size	L-640, W-315, H-270mm
Weight	14kg
Material	CRC Steel

Unique Features :

- TYRE BENCH SPREADER is used for inspection work by holding tyre beads apart while making section repairs on truck tyre.



4400620



4400620

GTS-01

Tyre Spreader for Commercial Vehicle Tyres | sarv

Unique Features :

- Ideal for quick and efficient tyre repairs on larger tyre sizes. For use with a manual wrench / ratchet wrench with 32 mm socket.

Technical Data	
Minimum jaw closure	25mm
Maximum jaw opening	325mm
Weight	2.7Kg

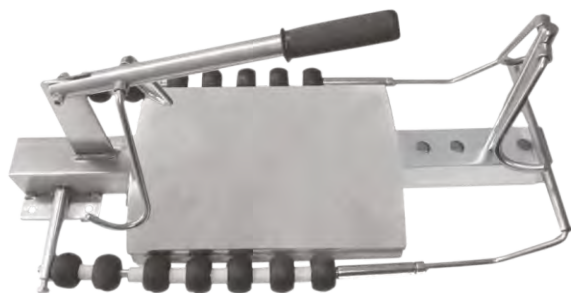

4400220

Tyre Bench Spreader | sarv

Unique Features :

- Holds the tube and provides a smooth base for processing. Spreads Truck/Buses tyres. Can be mounted on work bench. Suitable for very long stiff beads. High stability & strength.

Technical Data	
Size	L-600mm, W-290mm, H-250mm
Weight	6.500kg
Material	CRC Steel

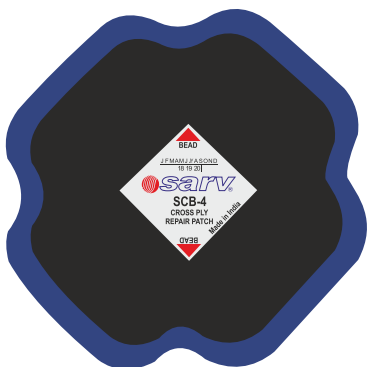

1 SCB-4



2 SCR-42



3 SBP-5

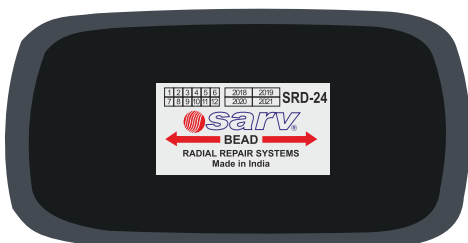

4 SRD-24

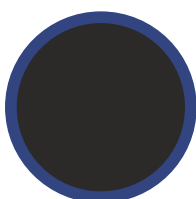

5 SCTR2

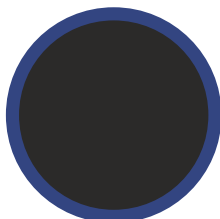

5 SCTR3

1 Bias Tyre Repair Patches (Chemical Cure)

Ply Rating:	Dia:	Qty/Box:	Code No.
4	160mm	10	SCB-4

Use : Permanent repair of the damage tyre.

Refer to Sarv Patches catalog for complete information.

2 Radial Tyre Repair Patches (Chemical Cure)

Ply Rating:	Size:	Qty/Box:	Code No.
4	125x250mm	5	SCR-42

Use : Permanent repair of the damage tyre.

Refer to Sarv Patches catalog for complete information.

3 Bias Tyre Repair Patches (Dual Cure)

Ply Rating:	Dia:	Qty/Box:	Code No.
4	170mm	10	SBP-5

Use : Permanent repair of the damage tyre.

Refer to Sarv Patches catalog for complete information.

4 Radial Tyre Repair Patches (Dual Cure)

Ply Rating:	Size:	Qty/Box:	Code No.
2	90x220mm	10	SRD-24

Use : Permanent repair of the damage tyre.

Refer to Sarv Patches catalog for complete information.

5 Tube Patches (Chemical)

Shape:	Size:	Qty/Box:	Code No.
Round	23mm	150	SCCP
Round	28mm	100	SCTR1
Round	30mm	50	SCTR2
Round	38mm	50	SCTR3
Round	48mm	25	SCTR4
Round	56mm	25	SCTR5
Round	75mm	25	SCTR6

Refer to Sarv Patches catalog for complete information.

6 Tube Patches (Chemical)

Shape:	Size:	Qty/Box:	Code No.
Oval	27X40mm	50	SCTO1
Oval	25X60mm	50	SCTO2
Oval	76X37mm	25	SCTO3
Oval	102X44mm	25	SCTO4

Refer to Sarv Patches catalog for complete information.



6 SCTO1

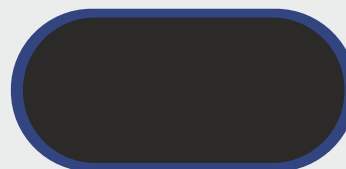

6 SCTO2



7 440127

7 TUBELESS TYRE REPAIR MUSHROOM PATCHES

Injury Size:	Patch Size:	Qty/Box:	Code No.
3mm	1/8"	40	440127
6mm	1/4"	40	440227
9mm	3/8"	40	440527

Refer to Sarv Patches catalog for complete information.



8 SPS3

8 SPS6

8 SPS9

8 TUBELESS TYRE REPAIR STEMS

Injury Size:	Patch Size:	Qty/Box:	Code No.
3mm	1/8"	40	SPS3
6mm	1/4"	30	SPS6
9mm	3/8"	25	SPS9
13mm	1/2"	20	SPS13
18mm	3/4"	10	SPS18
25mm	1"	10	SPS25
30mm	1 1/4"	10	SPS30

Refer to Sarv Patches catalog for complete information.



9 44RS06

9 44RS07



9 Repair Strings

Colour:	Size (Flap):	Weight:	Code No.
Brown	2" long	3gms	44RS06
Brown	4" long	15gms	44RS07
Black	4" long	15gms	44RS07BK
Brown	8" long	25gms	44RS08
Black	8" long	25gms	44RS08BK

Packaging: 1 flap consists of 5 repair Strings.



9 44RS07BK



9 44RS08



10 SC-704



11 SC-713

10 Chemical Vulcanizing Fluid (Sarv Sol)

Quantity:	Qty/Box:	Code No.
75 ml Tube	20	SC-701
300 ml Tin	10	SC-703
1 Litre Tin	6	SC-704

Refer to Sarv Patches catalog for complete information.



12 SC-706



13 SC-709

11 HD Chemical Cement (Sarv HD Blue)

Quantity:	Qty/Box:	Code No.
300 ml Tin	10	SC-712
1 Litre Tin	6	SC-713

Refer to Sarv Patches catalog for complete information.

12 Sarv Repair Sealer

Quantity:	Qty/Box:	Code No.
1 Litre Tin	6	SC-706

Refer to Sarv Patches catalog for complete information.

13 Sarv Bead Sealer

Quantity:	Qty/Box:	Code No.
1 Litre Tin	6	SC-709

Refer to Sarv Patches catalog for complete information.

BHEEM UNIVERSAL TYRE REPAIR KIT



S No.	Description	Packing	S No.	Description	Packing		
1	Drill Chuck (Short Adaptor)	85002-S	1	35	Nail extraction Plier	85028	1
2	Drill Chuck (Long Adaptor)	85002-L	1	36	Hammer	ST-HR	1
3	Cone Rasp, 16 GRIT	85003-16	1	37	1/2" Female FRL, 16bar	85029-16	1
4	Cone Rasp, 36 GRIT	85003-36	1	38	Recoil Hose (3/8")	ST-RH 3/8	1
5	Round face Rasp, 16 GRIT	85004-16	1	39	QRC 3/8" Female, Reducer 1/2"m 3/8" F	ST-QRC 3/8F	1
6	Round face Rasp, 36 GRIT	85004-36	1	40	1/4 " Male adaptor for QRC	ST-MA 1/4	1
7	Pencil Rasp, 16 GRIT	85005-16	1	41	Mechanical Hand Tyre spreader	4400620	1
8	Pencil Rasp, 36 GRIT	85005-36	1	42	Mask	85034	5
9	Cup Rasp, 36 GRIT	85006-36	1	43	Goggles	85035	2
10	Rotary Gouger	85007-50	1	44	Gloves	85036	3
11	Taper Point Skiver	85008	1	45	Steel Scale, 12"	85037-12	1
12	Extra Curve Skiver	85009	1	46	Tool Box	85038	1
13	Round Point Skiver	85010	1	47	Wooden Tyre stand	85039	1
14	Spiral Cementing Tool	4400014	1	48	CVF 200ml	SC-703	5
15	Rubber Scrapper	440005BK	1	49	200ml cleaning agent	ST-ROM	6
16	Stitcher	443861	1	50	Vulgum	SRM-802	1
17	Point End Burr	85011-3	1	51	Adhesive Solution	ST-TEM	1
18	Router Carbide Burr	85012-3	1	52	Carbide Cutter, 3mm	85044-3	1
19	Pencil Mounted Stone	85013	1	53	Carbide Cutter,6mm	85044-6	1
20	Mushroom Mounted Stone 40MM	85014-40	1	54	Low speed Pneumatic buffer	85045-L	1
21	Mushroom Mounted Stone 30MM	85014-30	1	55	High speed Pneumatic buffer	85046-H	1
22	Conical mounted stone	85015	1	56	Radial patch, SRD 20 90X130	SRD 20	20
23	Encapsulated brush	85016	1	57	Radial patch, SRD22 100X180	SRD 22	10
24	3" Brush	850217	1	58	Radial patch, SRD24 90X220	SRD 24	10
25	Skiving brush	85018	1	59	Radial patch, SRD26 100X250	SRD 26	10
26	Carbide Cutter, 10mm	85044-10	1	60	Radial Patch, SRD33 110X135	SRD 33	10
27	Carbide Cutter, 13mm	85044-13	1	61	Radial patch, SRD35 125X150	SRD 35	10
28	Wire Puller	85021	2	62	Radial patch, SRD40 110X200	SRD 40	20
29	Electric drill machine, 13mm	85022-13	1	63	Radial patch, SRD42 120X250	SRD 42	5
30	Tyre Vulcanizing Machine	85023	1	64	Radial patch, SRD44 135X330	SRD 44	5
31	Cleaning brush	850217	3	65	Mushroom Patch Bias and radial, 3mm	440127	40
32	Scissors	85025	1	66	Mushroom Patch Bias and radial, 6mm	440227	40
33	Screw Driver	ST-SDB	1	67	Mushroom Patch Bias Only, 9mm	440527	40
34	Cutting Pliers	85027	1				

SOLUTIONS FOR

 Vehicle Garages

 Professional Tyre Shops

 Garage Equipment Manufacturers



Scan for Download Latest Catalog

Wheel Balancing Accessories

 IN HOUSE MANUFACTURING



Wheel Balancing Weight Plier
110011 / 110101



Adhesive Weight Removing Plier
110204



PCD Measuring Tool
110025 / 110015



Sarv-Quick Locking Nut with Inserts
WB403



Truck Adapter Kit Cones for Wheel Balancing
11202281



Self Centering Cone
11951854



Wheel Clamping Cup
1104060 / 1104070



Rim Width Caliper (for Trucks)
1100010



Wheel Balancing Weights for Alloy Rims and Steel Rims



Wheel Balancing Sticker Weights for Alloy Rims
1100058 / 1100050

Wheel Alignment Accessories

 IN HOUSE MANUFACTURING

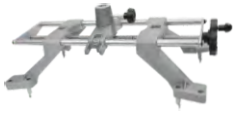

Wheel Clamp for Measuring Head
5521024



Finger Tools (Claws) for Wheel Clamp
550127 / 550227 / 550218



Mechanical Turn Table with Scale
1100317



Mechanical Turn Table with Scale, Ramp
1101117



Mechanical Turn Table (Heavy Duty)
1100217



Wheel Clamp for Measuring Head
5531024



Brake Pedal Depressor
111184



Steering Wheel Holder
112384

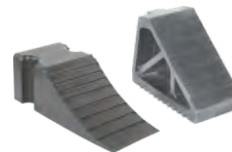

Rubber Wheel Chock
553004 / 554504

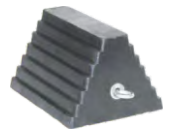

Rubber Wheel Chock
551904

Tyre Changing Accessories

 IN HOUSE MANUFACTURING



Wheel Flange Loosener
220204 / 2202045



Lug Nut Cap Puller
220057 / 220067



Double Ended Wheel Wrench for Trucks
2227336 / 2230336



Four Way Wheel Nut Wrench for Trucks
2200014



Clamping Jaws for Truck Tyre Changers
2220688

MANUFACTURING AND EXPORTS TO 90+ COUNTRIES SINCE 1991



**WORLDWIDE
PRESENCE**

AUTHORIZED DISTRIBUTOR

STANLEY®

HAND TOOLS & STORAGE



Professional Tyre Tools & Equipments Since 1991

FULL RANGE OF
GARAGE ACCESSORIES
by sarv

INDIA'S FIRST E-OUTLET
ORDER ONLINE
[@www.garageequipments.com](http://www.garageequipments.com)

Sarveshwari Technologies Ltd.

355 Deepali, Pitampura, Delhi - 110 034 (INDIA)
Tel.: 91-11-27915432, 91-11-27915987
Toll Free Helpline : 1800-11-3750
Web: www.garageequipments.com
E-mail: info@garageequipments.com



or Log on to
www.garageequipments.com



or Like our
Facebook Page
Sarveshwari Technologies Limited



or Subscribe to our
YouTube Channel
Sarveshwari Technologies Limited